

JBC

www.jbctools.com

INSTRUCTION MANUAL



UCR

General/Heavy Duty Control Unit
for Robot

This manual corresponds to the following references:

UCR245-5A
UCR470-5A

Packing List

Either Ref. UCR245-5A or Ref. UCR470-5A is included in UCR unit:



Control Unit for Robot 1 unit



Tool Cable 3m 1 unit
Ref. 0027924



Communications Cable 3m 1 unit
Ref. 0024563



Power Cord 1.5m 1 unit
Ref.0023715 (100V/200V)
0023714 (230 V)



Manual 1 unit
Ref. 0027876

Functions

There are up to 44 functions* to control the station, such as:

- Temperature Control
- Sleep and Hibernation Control
- Station Status
- Error Information
- Counters (Working Time, Sleep, Hibernation...)

*Download the Robot Communication Protocol for UCR unit at www.jbctools.com/jbcsoftware.html

Features

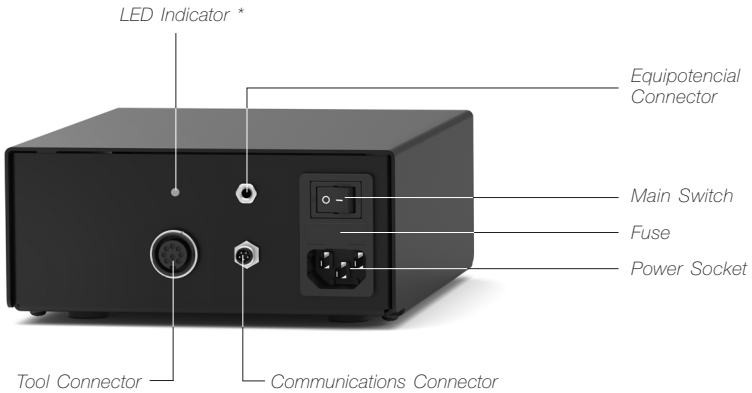

**LED Indicator:*

- Blue: equipment powered
- Green: equipment working
- Red blinking: error. See table below for more info.

Trouble shooting

In case of error, a red light flashes a certain number of times, indicating an error number as shown in the table below:

N° Error	Description	Solution
1 time	Short-circuit	Replace Cartridge
2 times	Open circuit	Replace Cartridge
3 times	Tool not accepted	Check if the tool is compatible with the Control Unit
4 times	Tool detection error	Check the tool
6 times	Current usage leads to overloading	Due to overload wait until the device has cooled down
7 times	Short-circuit	Check if the cartridge is compatible with the Control Unit
12 times	Memory error	Reset the Control Unit

If the error persists, contact with JBC technical service.

Connection

- UCR can be connected to a PLC by a five-pin Communications Cable (Ref. 0020261).
- For a proper connection, it is necessary to connect only three cables to the corresponding 3 pins at a typical DB9 male connector (PLC or computer).
- Download the Robot Communication Protocol at www.jbctools.com

Communications Cable

Ref. 0020261

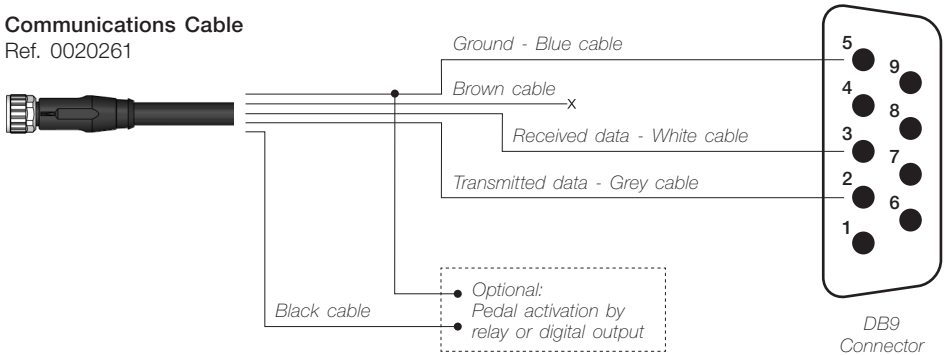

For detailed information about pin distribution see following table:

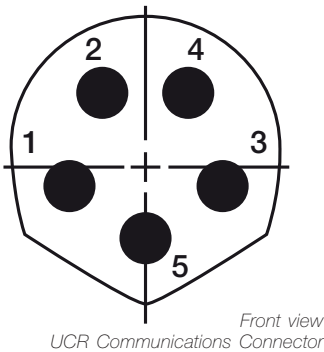

Pin Distribution		
Pin	Color	Description
1	Brown	Not used
2	White	Serial input: RS232 RX
3	Blue	Common reference: GND for RS232 and witch
4	Black	Switch input: 0V or 24V to start feeding. Leave it open to stop
5	Grey	Serial output: RS232 TX

Compatibility

UCR245/470 can be used with soldering irons, **TR245/470** and **TRA245/470**, and its cartridge ranges **R245** and **R470** respectively. Connect any of those soldering irons with the provided tool cable (Ref. 0027924). See the table below to check the compatibility of the devices.



Ref. TR245-A/ TR470-A



Ref. TRA245-B/ TRA470-B

Control Unit	Cartridge Range		Soldering Irons				Cartridge Stand	
	R245	R470	TR245	TR470	TRA245	TRA470	CSR245	CSR470
UCR245	●		●		●		●	
UCR470		●		●		●		●

SFR, GSFR and CLMR are compatible with R245 and R470 cartridge ranges.

Dimensions

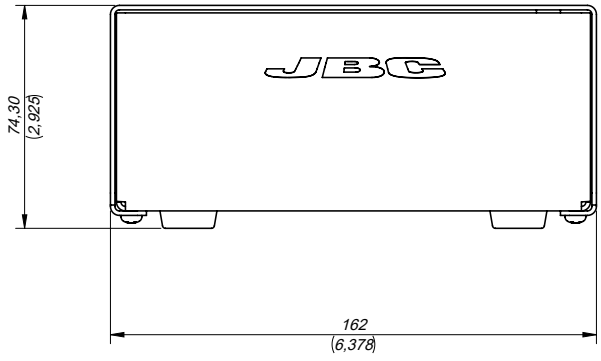
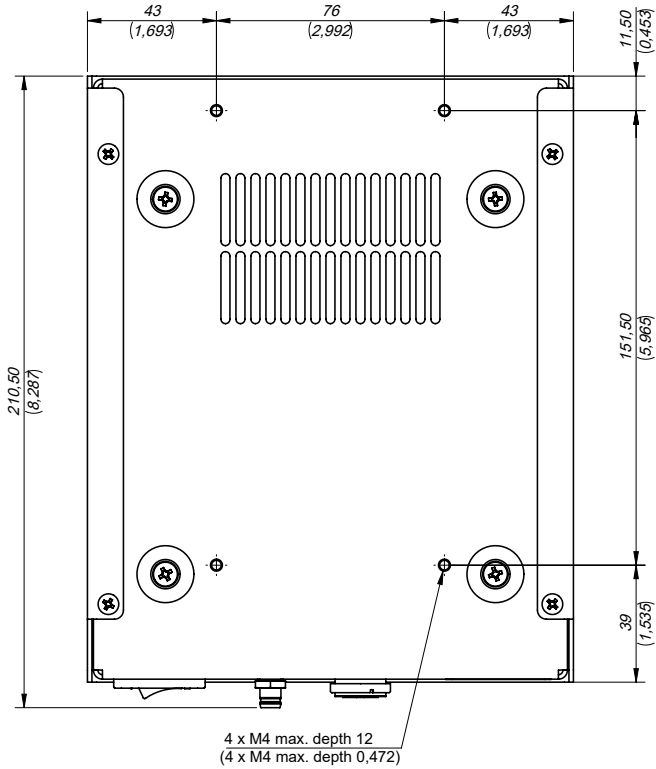

mm
(in)

Work Place Example

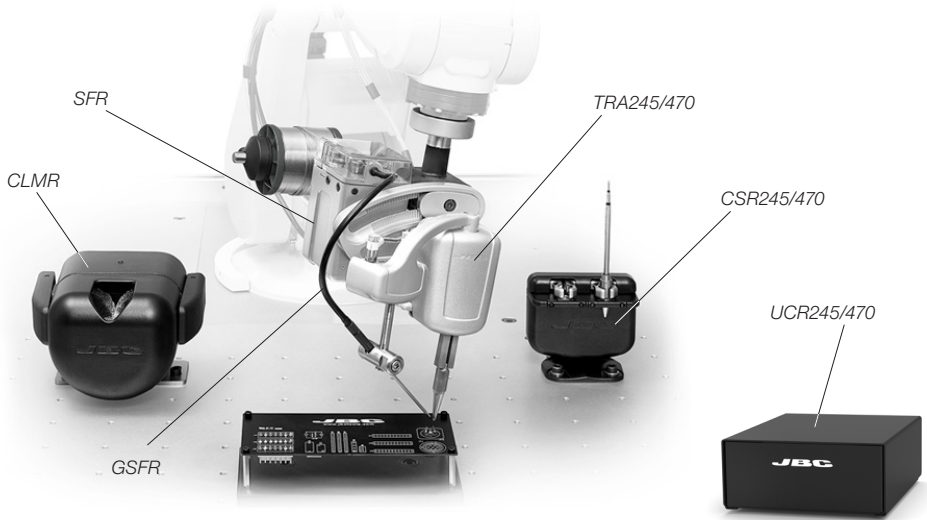

Maintenance

- Before carrying out maintenance, always disconnect the power supply and allow the equipment to cool down.
- Periodically check all cable and tube connections.
- Replace any defective or damaged parts. Only use original JBC spare parts.
- Repairs should be performed only by a JBC authorized technical service.
- A blown fuse can be replaced by the user itself.

The fuse is located between the power supply connector and the on/off switch (1). To replace a blown fuse, proceed as described below.

⚠ Important: make sure that the control unit is disconnected from the power supply.

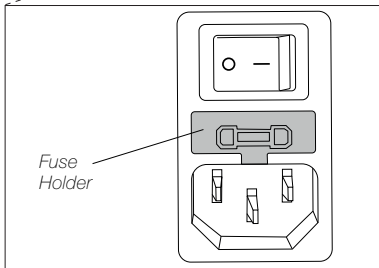
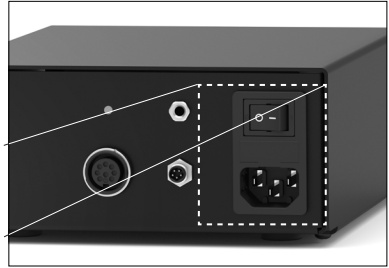

Pull out the fuse holder, if necessary use a tool to lever it off.

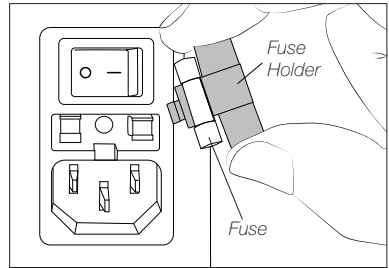

Take the blown fuse out and press the new one into the fuse holder. Finally clip the fuse holder back into place.

Safety



It is imperative to follow safety guidelines to prevent electric shock, injury, fire or explosion.

- Do not use the equipment for any purpose other than soldering or rework. Incorrect use may cause fire.
- The main cable must be plugged into approved bases. Make sure that it is properly grounded before use. When unplugging it, hold the plug, not the wire.
- Do not work on electrically live parts.
- Do not leave the appliance unattended while it is on.
- Be sure that the power supply is disconnected before changing any spare parts.
- The temperature of accessible surfaces may remain high after the device is turned off. Handle with care.
- Heat can cause inflammable products to ignite even when not visible.
- Avoid flux coming into contact with skin or eyes to prevent irritation.
- Be careful with the fumes produced when soldering.
- Keep your workplace clean and tidy. Wear appropriate protection glasses and gloves when working to avoid personal harm.
- Utmost care must be taken with liquid tin waste which can cause burns.

Specifications

UCR

Control Unit for Robot

Ref.: **UCR245-5A**

Ref.: **UCR470-5A**

UCR245-5A 100 - 240V 50/60Hz. Input fuse: 2.5A. Output: 21V.

- Output Peak Power: 160W
- Temperature Range: 90 - 450 °C / 190 - 840 °F
- Total Net Weight: 2581 g / 5.69 lb
- Package Dimensions/Weight:
(L x W x H) 328 x 258 x 208 mm / 3160 g
12.91 x 10.16 x 8.019 in / 6.97 lb

UCR470-5A 100 - 240V 50/60Hz. Input fuse: 3.5A. Output: 42V.

- Output Peak Power: 250W
- Temperature Range: 90 - 500 °C / 190 - 930 °F
- Total Net Weight: 2635 g / 5.81 lb
- Package Dimensions/Weight:
(L x W x H) 328 x 258 x 208 mm / 3215 g
12.91 x 10.16 x 8.019 in / 7.09 lb

UCR245-5A and UCR470-5A

- Idle Temp. Stability (still air): ± 1.5 °C / ± 3 °F
- Tip to ground resistance: < 2 ohms
- Tip to ground voltage: < 2mV RMS
- Ambient operating temp: 10 - 40 °C / 50 - 104 °F
- Connections: Communications: M8-5pins
Tool: M16-8pins
- Unit Dimensions:
(L x W x H) 210 x 162 x 75 mm
8.3 x 6.4 x 3.0 in

Complies with CE standards.
ESD safe.

JBC

Warranty

JBC's 2 year warranty covers this equipment against all manufacturing defects, including the replacement of defective parts and labour.

Warranty does not cover product wear or misuse.

In order for the warranty to be valid, equipment must be returned, postage paid, to the dealer where it was purchased.

Get 1 extra year JBC warranty by registering here:
<https://www.jbctools.com/productregistration/>
within 30 days of purchase.



This product should not be thrown in the garbage.

In accordance with the European directive 2012/19/EU, electronic equipment at the end of its life must be collected and returned to an authorized recycling facility.

CE EAC UK
CA

www.jbctools.com

0027876-280224