

JBC

www.jbctools.com

INSTRUCTION MANUAL



ALE250

Auto-Feed Soldering Iron

This manual corresponds to the following reference:

- ALE250-A

Packing List

The following items are included:



Auto-Feed Soldering Iron 1 unit

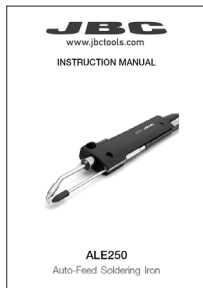

Manual 1 unit
Ref. 0028271

Features and Connections



* Control Unit, Cartridge and Guide Set not included

Compatible Cartridges

ALE250 works with C250 cartridges. Find the model that best suits your soldering needs at www.jbctools.com

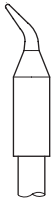

Conical Bent



Chisel



Chisel Bent



Bevel

Cartridge Assembly

Loosen the cartridge fixation screw (1). Insert the cartridge up to the mark (2) and then gently push it (3) in until it comes to a stop.

Important: It is essential to insert the cartridge completely for a good connection.

Adjust the cartridge position (4) and tighten the cartridge fixation screw (1)

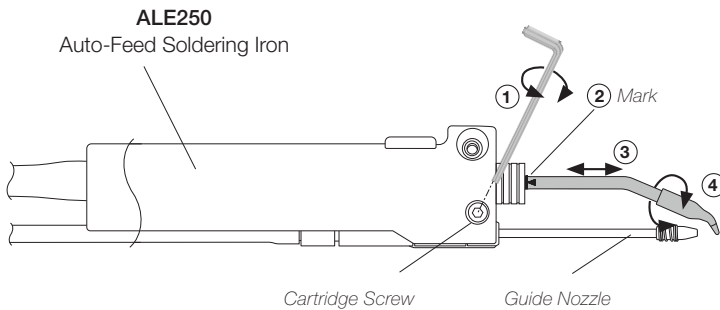

Guide Tube Set Assembly

Open the guide tube set fixation screw (1) and insert the guide tube set.

Adjust the guide tube length (2). Leave a gap of 5 to 7 mm (0.19 to 0.27 in) between the tip and the outlet nozzle (3). Once the position is adjusted tighten the guide tube set screw (1).

For a better handling use the clips (4) to attach the guide tube to the tool cable.

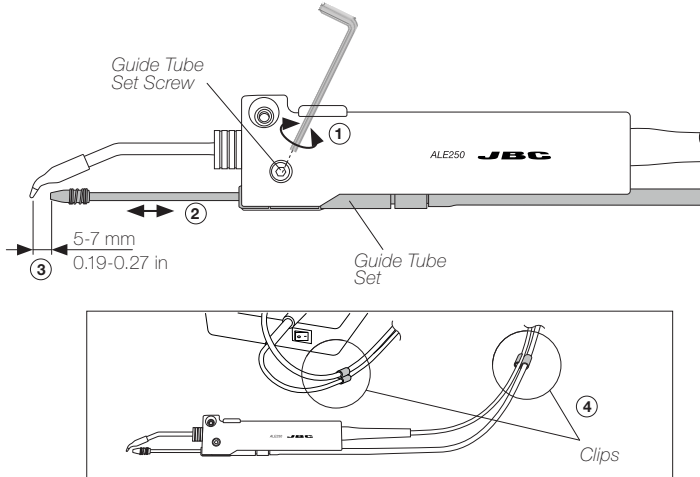

Tool Assembly

Connect the tool to the control unit following these steps:

Loosen the set screw, insert and push the guide nozzle until it stops (1) and tighten the set screw (2) again. Then plug in the tool connector (3).

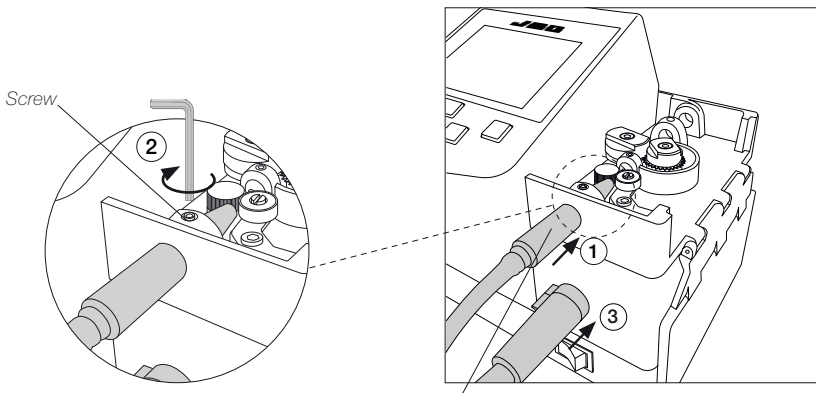

Insert all the way in until it stops

Solder Reel Assembly

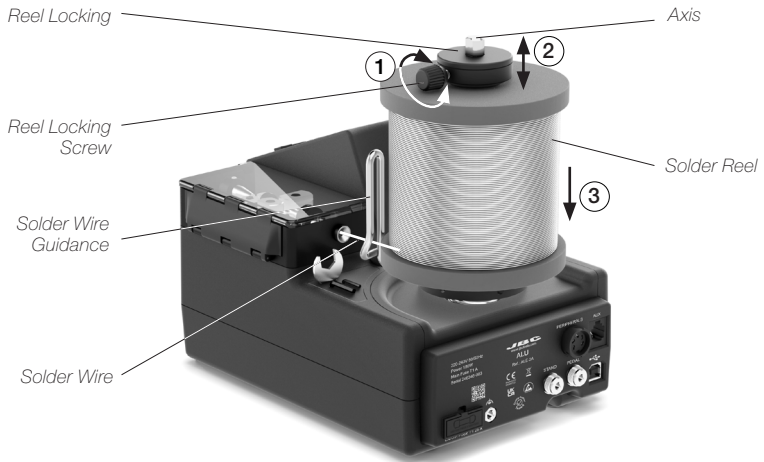

Loosen the reel locking screw (1) and remove the reel locking (2) from the axis.

Assemble the solder reel onto the axis (3).

⚠ Insert the solder reel in such a way - when viewed from above - that the solder wire unwinds on the dispensing mechanism side (4).

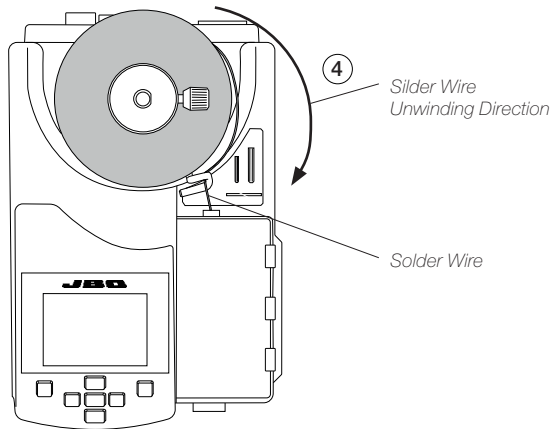

To assemble the reel locking, its conical side must be pointing downwards.

Align the flat side of the axis (5) with the inner flat side (the one with the screw) of the reel locking and reassemble it to the axis (6).

Note: To prevent the solder reel from spinning freely or binding, before tightening the reel locking screw gently press the reel locking down, but only enough to have the solder reel secured in place.

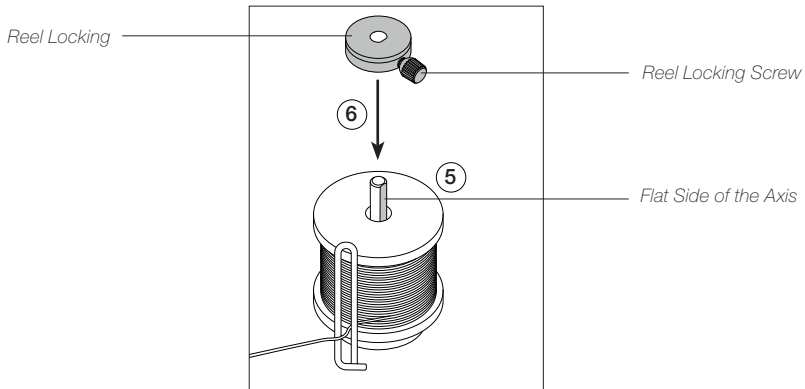

Main Menu Screen

Access to Main Menu by pressing , select "Feeder settings" (1) and then "Wire diameter" (2) to adjust the value to the current solder wire diameter.

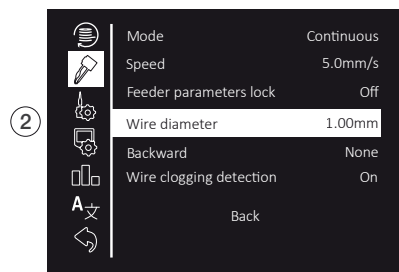
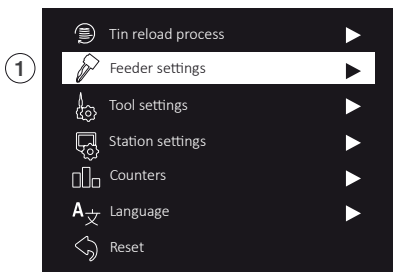

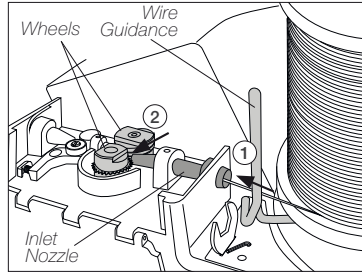

Solder Wire Loading

Pass the solder wire through the wire guidance and introduce the solder wire into the inlet nozzle (1) until it reaches the wheels (2).

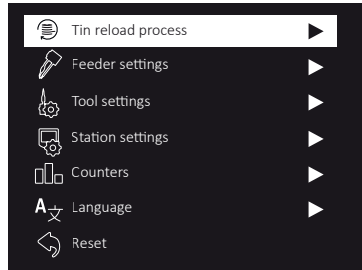

Select “Tin reload process” and then use  to feed the solder wire and advance until it comes out of the outlet nozzle.



If needed, carefully push the wire until it gets locked in between the rotating wheels for the wire to start moving forward. Keep  pressed and after a while, the wire will advance faster.

Make sure the wire passes through the intermediate nozzle (3) and enters the guide tube (4).

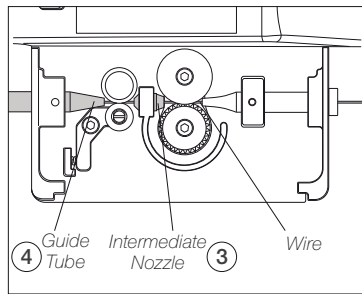

Solder Wire Feeding

Forward the solder wire by pressing the dragging button (1) until the wire comes out of the tip (2).

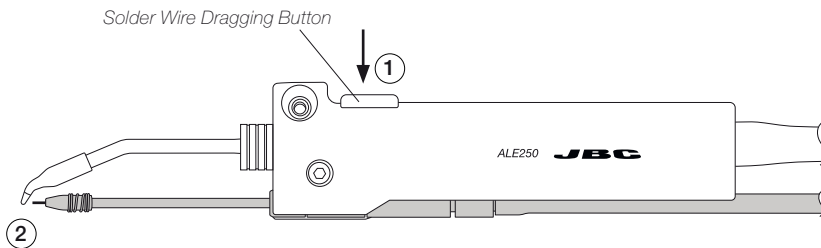

Alternatively, solder wire can also be fed using the pedal P405. The pedal should be plugged in at the rear of the feeder control unit into the pedal connector.



Solder Wire Unloading

With Solder Wire Perforation

To unload solder wire with perforation that has already passed through the guide tube, cut the wire between the wire guidance and the inlet nozzle (1).

To extract the wire out of the tube, hold the tool on your hand and press  until the wire stops moving forward.

Grasp the wire coming out of the outlet nozzle with a pliers and pull from it until it is completely out.

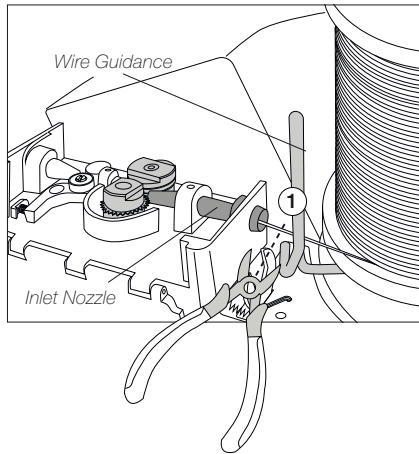

Without Solder Wire Perforation

When using a kit without solder wire perforation, press  until the wire is completely wound to unload the solder wire. It is best to rotate the reel by hand as the wire is being pulled back in order to keep it neatly arranged on the reel.

Or, if preferred, proceed as described before for perforated solder wire unloading.

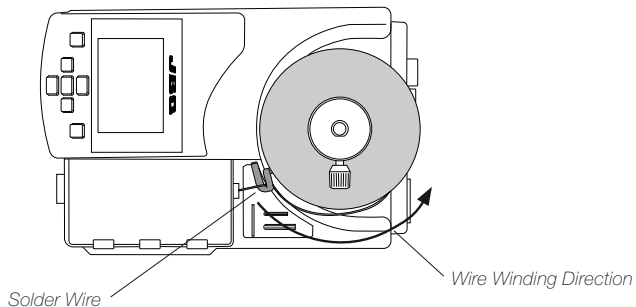

Changing Cartridges

 For a safe cartridge change, unplug the tool or turn the station off before following these guidelines:

Loosen the cartridge screw (1) to release the cartridge (2). Place a new one into the auto-feed iron.

Important: It is essential to insert the cartridge up to the end for a good connection. Use the mark as reference (3).

Align the tip of the cartridge with the guide nozzle (4) and tighten the cartridge screw (1)

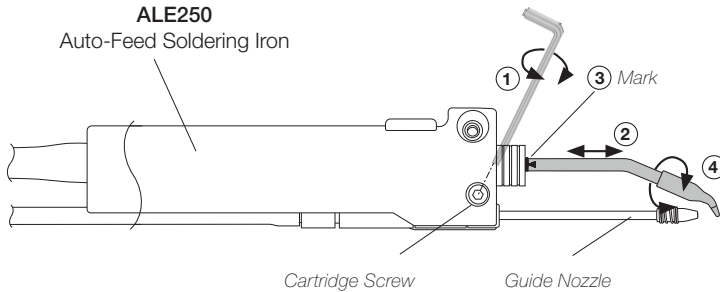

Replacing Guide Sets

Once the tool is disconnected from the control unit and has cooled down, follow these instructions:

Unload the solder wire and disassemble the outlet nozzle (1) from the guide set.

Loosen the guide tube set screw (2), take out the guide set (3) and insert the desired one.

Put the outlet nozzle (1) back on the new guide nozzle. Leave a gap of 5 to 7 mm (0.19 to 0.27 in) between the cartridge tip and the outlet nozzle (4).

Once the guide nozzle length is adjusted tighten the guide set screw (2).

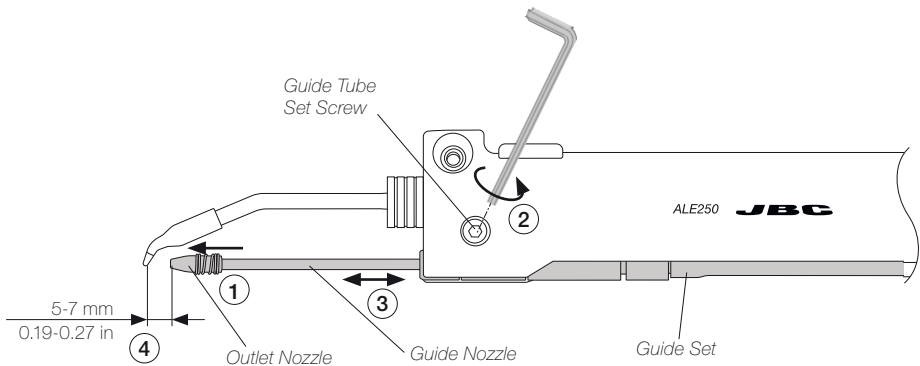

Outlet Nozzle Replacement

Flux can cause clogging at the outlet nozzle of the guide tube set and it can be necessary to replace the worn or clogged outlet nozzle.

Note: There is a nozzle size for each soldering wire diameter. The use of the nozzle is necessary as its inner diameter is adjusted to the solder wire diameter and guides the wire with greater precision.

To replace the outlet nozzle, follow these steps:

First, make sure that the tool has cooled down and unload any remaining solder wire that might still be inside the guide tube (see page 9). Unplug the tool. Loosen the guide tube set screw (1) and detach the guide tube set from the tool for easier handling.

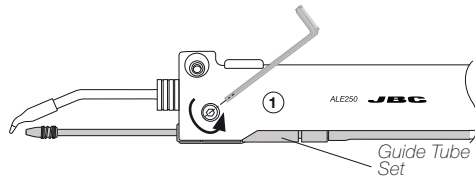

Unscrew the spring inwards (2), following the downward direction of the spring.

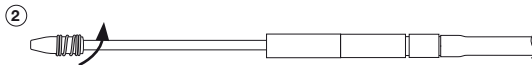

Once the outlet nozzle is released from the spring, pull the outlet nozzle out (3) and then remove the spring (4).

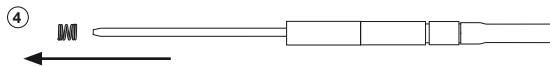
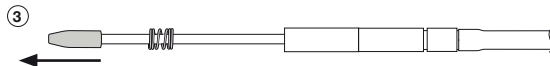

Place the new outlet nozzle onto the guide tube set (5).



Once the outlet nozzle is set in place, screw the spring onto it to fix the outlet nozzle onto the guide tube (6).

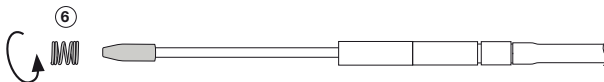

GALEXXV-A WITH SOLDER WIRE PERFORATION



XX	Wire diameter
	Diameter of use
08	Ø0.8 mm / Ø0.032 in
10	Ø1.0 mm / Ø0.040 in
12	Ø1.2 mm / Ø0.047 in
15	Ø1.5 mm / Ø0.059 in
16	Ø1.6 mm / Ø0.063 in

Guide tube
GALE08V-A / 0028359
GALE10V-A / 0028360
GALE12V-A / 0028361
GALE15V-A / 0028362
GALE16V-A / 0028363

SPARE PARTS

Solder Wire Ø Range	Wire Ø	Outlet nozzle	Nozzle	Guide wheel	Blade	Blade clamp	Inlet nozzle	Interm. nozzle	Counter wheel	Screws	Threaded stud
0.8 mm / 0.032 in	GALE08V-A	0025270	0030913	0021686 0021689 0023738 0019686 0025922	0021555	0018638	0018632	0024955	0026693 0026694	0026695 (x2) 0026696 (x3)	0026696 (x3)
1.0 mm / 0.040 in	GALE10V-A	0021560					0019170	0024956			
1.2 mm / 0.047 in	GALE12V-A	0025272					0019171	0024957			
1.5 mm / 0.059 in	GALE15V-A	0025274					0024233	0024958			
1.6 mm / 0.063 in	GALE16V-A	0025276						0024959			

GALE Guide Kits for ALE250

GALEXXD-A WITHOUT SOLDER WIRE PERFORMANCE

XX	Wire diameter	Range of Use
04	Ø 0.38 - 0.40 mm	Ø 0.015 - 0.016 in
05	Ø 0.46 - 0.56 mm	Ø 0.018 - 0.022 in
06	Ø 0.60 - 0.64 mm	Ø 0.023 - 0.025 in
07	Ø 0.70 - 0.78 mm	Ø 0.028 - 0.031 in
08	Ø 0.80 - 0.82 mm	Ø 0.032 - 0.033 in
10	Ø 0.90 - 1.10 mm	Ø 0.036 - 0.044 in
12	Ø 1.14 - 1.27 mm	Ø 0.045 - 0.051 in
15	Ø 1.50 - 1.57 mm	Ø 0.060 - 0.063 in
16	Ø 1.60 - 1.63 mm	Ø 0.063 - 0.065 in
18	Ø 1.80 mm	Ø 0.073 in



Guide tube	
GALE04D-A	0032405
GALE05D-A	0026358
GALE06D-A	0028481
GALE07D-A	0028492
GALE08D-A	0026359
GALE10D-A	0026360
GALE12D-A	0026361
GALE15D-A	0026362
GALE16D-A	0026363
GALE18D-A	0028483

SPARE PARTS

Solder Wire Ø Range	Wire Ø	Outlet nozzle	Nozzle	Traction wheel	Support wheel	Inlet nozzle	Interm. nozzle	Counter wheel	Screws	Threaded stud
0.38 - 0.40 mm / 0.015 - 0.016 in		0022912			0020345		0024954			
0.46 - 0.56 mm / 0.018 - 0.022 in		0023266			0019519	0019520	0025293	0026693	0026695 (42)	0026696 (43)
0.60 - 0.64 mm / 0.023 - 0.025 in		0023864				0018632	0025291			
0.70 - 0.78 mm / 0.028 - 0.031 in		0023269			0019480	0019170	0024955			
0.80 - 0.82 mm / 0.032 - 0.033 in		0023270	0030913	0019479		0019171	0024956			
0.90 - 1.10 mm / 0.036 - 0.044 in		0021560			0019481		0024957	0026694		
1.14 - 1.27 mm / 0.045 - 0.051 in		0023272				0024233	0024958			
1.50 - 1.57 mm / 0.060 - 0.063 in		0023274			0028367		0024959			
1.60 - 1.63 mm / 0.063 - 0.065 in		0023276					0024959			
1.80 mm / 0.073 in		0021569				0024234	0024960			

Accessories

Fume Extractor

Ref. F4468 - 2 m (78.74 ft) length.

The fume extractor for AL250 is an easy & safe solution to suck the fume generated at the solder joint.

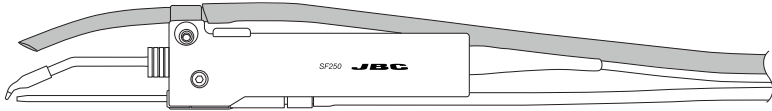

Maintenance

- Before carrying out maintenance, always unplug the stand and the tool.
- Check periodically that the metal parts of the tool and the stand are clean to ensure detection of the tool when it is in the stand. Use a damp cloth or alcohol.
- Periodically check all cables and tubes connections.
- Replace any defective or damaged pieces. Use original JBC spare parts only. Repairs should only be performed by a JBC authorized technical service.

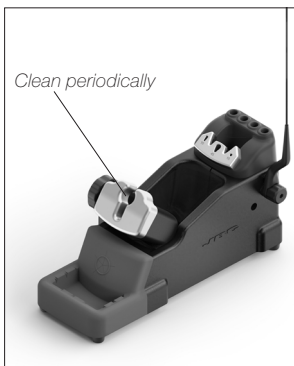

Safety



It is imperative to follow safety guidelines to prevent electric shock, injury, fire or explosion.

- Do not use the tool for any purpose other than soldering or rework.
- The power cord must be plugged into approved bases. Be sure that it is properly grounded before use. When unplugging it, hold the plug, not the wire.
- The tool should be placed in the stand when not in use in order to activate the sleep mode. The soldering tip, the metal part of the tool and the stand may still be hot even when the station is turned off. Handle with care, including when adjusting the stand position.
- Avoid the contact of flux with skin or eyes to prevent irritation.
- Be careful with the fumes produced when soldering.
- Keep your workplace clean and tidy. Wear appropriate protection glasses and gloves when working to avoid personal harm.
- Utmost care must be taken with liquid tin waste which can cause burns.
- This appliance can be used by children over the age of eight and also persons with reduced physical, sensory or mental capabilities or lack of experience provided that they have been given adequate supervision or instruction concerning use of the appliance and understand the hazards involved. Children must not play with the appliance.
- Maintenance must not be carried out by children unless supervised.

Specifications

ALE250

Auto-Feed Soldering Iron

Ref.: ALE250-A

- | | |
|---|---|
| - Tool Dimensions (aprox.): | 35 x 21 x 182 mm / 1.42 x 0.83 x 7.16 in |
| - Total Net Weight: | 148 gr / 0.33 lb |
| - Package Dimensions / Weight:
(L x W x H) | 300 x 125 x 65 mm / 257 g
11.81 x 4.92 x 2.56 in / 0.57 lb |

Complies with CE standards.
ESD safe.

JBC

Warranty

JBC's 2 year warranty covers this equipment against all manufacturing defects, including the replacement of defective parts and labour.

Warranty does not cover product wear or misuse.

In order for the warranty to be valid, equipment must be returned, postage paid, to the dealer where it was purchased.



This product should not be thrown in the garbage.

In accordance with the European directive 2012/19/EU, electronic equipment at the end of its life must be collected and returned to an authorized recycling facility.



www.jbctools.com