



## ALE

### Automatic-Feed Soldering Station

This Plug & Play Guide corresponds to the following references:

①

Station **with** Solder Wire Perforation

Ref.
ALE-908VA (100 V)
ALE-108VA (120 V)
ALE-208VA (230 V)
ALE-910VA (100 V)
ALE-110VA (120 V)
ALE-210VA (230 V)
ALE-912VA (100 V)
ALE-112VA (120 V)
ALE-212VA (230 V)
ALE-915VA (100 V)
ALE-115VA (120V)
ALE-215VA (230 V)
ALE-916VA (100 V)
ALE-116VA (120 V)
ALE-216VA (230 V)

②

Station **without** Solder Wire Perforation

Ref.	Ref.
ALE-904A (100 V)	ALE-910A (100 V)
ALE-104A (120 V)	ALE-110A (120 V)
ALE-204A (230 V)	ALE-210A (230 V)
ALE-905A (100 V)	ALE-912A (100 V)
ALE-105A (120 V)	ALE-112A (120 V)
ALE-205A (230 V)	ALE-212A (230 V)
ALE-906A (100 V)	ALE-915A (100 V)
ALE-106A (120 V)	ALE-115A (120 V)
ALE-206A (230 V)	ALE-215A (230 V)
ALE-907A (100 V)	ALE-916A (100 V)
ALE-107A (120 V)	ALE-116A (120 V)
ALE-207A (230 V)	ALE-216A (230 V)
ALE-908A (100 V)	ALE-918A (100 V)
ALE-108A (120 V)	ALE-118A (120 V)
ALE-208A (230 V)	ALE-218A (230 V)

#### Station

More Information at the  
product web page



#### Video Guide

Watch the  
product video



1 **With** Solder Wire Perforation

**Packing List:**



Purchased Station Ref.	Control Unit * Ref.	Suitable for Solder Wire:
ALE-908VA (100 V) ALE-108VA (120 V) ALE-208VA (230 V)	ALE-908UVA (100 V) ALE-108UVA (120 V) ALE-208UVA (230 V)	Ø 0.8 mm / Ø 0.032 in
ALE-910VA (100 V) ALE-110VA (120 V) ALE-210VA (230 V)	ALE-910UVA (100 V) ALE-110UVA (120 V) ALE-210UVA (230 V)	Ø 1.0 mm / Ø 0.040 in
ALE-912VA (100 V) ALE-112VA (120 V) ALE-212VA (230 V)	ALE-912UVA (100 V) ALE-112UVA (120 V) ALE-212UVA (230 V)	Ø 1.2 mm / Ø 0.047 in
ALE-915VA (100 V) ALE-115VA (120V) ALE-215VA (230 V)	ALE-915UVA (100 V) ALE-115UVA (120V) ALE-215UVA (230 V)	Ø 1.5 mm / Ø 0.060 in
ALE-916VA (100 V) ALE-116VA (120 V) ALE-216VA (230 V)	ALE-916UVA (100 V) ALE-116UVA (120 V) ALE-216UVA (230 V)	Ø 1.6 mm / Ø 0.063 in

Content\*

*\*One of the listed control unit references is included according to the purchased station reference.*

**Note:**

A solder wire guide kit is included inside the control unit package and the guide wheels are already installed in the control unit.

Other solder wire guide kits for different solder wire diameters are available at [www.jbctools.com/solder-wire-guide-product-2098.html](http://www.jbctools.com/solder-wire-guide-product-2098.html)

**GALExxV**  
Solder Wire Guide Kit for ALE250  
with perforation

**GALExxD**  
Solder Wire Guide Kit for ALE250



The following items are included in **all** purchased station references (1 unit of each item):



**ALE250** Automatic-Feed Soldering Iron  
Ref. ALE250-A



**ALES** Stand for ALE250  
Automatic-Feed Soldering Iron  
Ref. ALE-SA



**C250403** Conical Bent Cartridge Ø 1  
Ref. C250403

② **Without** Solder Wire Perforation

**Packing List:**



Station Ref.	Control Unit *	Suitable for Solder Wire:
ALE-904A (100 V) ALE-104A (120 V) ALE-204A (230 V)	ALE-904UA (100 V) ALE-104UA (120 V) ALE-204UA (230 V)	wire Ø 0.38 - 0.4 mm / 0.015 - 0.016 in
ALE-905A (100 V) ALE-105A (120 V) ALE-205A (230 V)	ALE-905UA (100 V) ALE-105UA (120 V) ALE-205UA (230 V)	wire Ø 0.45 - 0.56 mm / 0.018 - 0.022 in
ALE-906A (100 V) ALE-106A (120 V) ALE-206A (230 V)	ALE-906UA (100 V) ALE-106UA (120 V) ALE-206UA (230 V)	wire Ø 0.6 - 0.64 mm / 0.023 - 0.025 in
ALE-907A (100 V) ALE-107A (120 V) ALE-207A (230 V)	ALE-907UA (100 V) ALE-107UA (120 V) ALE-207UA (230 V)	wire Ø 0.7 - 0.78 mm / 0.028 - 0.031 in
ALE-908A (100 V) ALE-108A (120 V) ALE-208A (230 V)	ALE-908UA (100 V) ALE-108UA (120 V) ALE-208UA (230 V)	wire Ø 0.8 - 0.82 mm / 0.032 - 0.033 in
ALE-910A (100 V) ALE-110A (120 V) ALE-210A (230 V)	ALE-910UA (100 V) ALE-110UA (120 V) ALE-210UA (230 V)	wire Ø 0.9 - 1.1 mm / 0.036 - 0.044 in
ALE-912A (100 V) ALE-112A (120 V) ALE-212VA (230 V)	ALE-912UA (100 V) ALE-112UA (120 V) ALE-212UA (230 V)	wire Ø 1.14 - 1.27 mm / 0.045 - 0.051 in
ALE-915A (100 V) ALE-115A (120 V) ALE-215A (230 V)	ALE-915UA (100 V) ALE-115UA (120 V) ALE-215UA (230 V)	wire Ø 1.5 - 1.57 mm / 0.06 - 0.063 in
ALE-916A (100 V) ALE-116A (120 V) ALE-216A (230 V)	ALE-916UA (100 V) ALE-116UA (120 V) ALE-216UA (230 V)	wire Ø 1.6 - 1.63 mm / 0.063 - 0.065 in
ALE-918A (100 V) ALE-118A (120 V) ALE-218A (230 V)	ALE-918UA (100 V) ALE-118UA (120 V) ALE-218UA (230 V)	wire Ø 1.8 mm / 0.073 in

Content\*

\*One of the listed control unit references is included according to the purchased station reference.

The following items are included in **all** purchased station references (1 unit of each item):



**P405 Pedal**  
Ref. P-405



**SCH Cartridge Holder**  
Ref. SCH-A



**PLR195 Cartridge Extractor Plier**  
Ref. PLR195

## Installation

Before you can start working, the solder reel\* must be attached and the tool stand, the soldering iron and the power cord connected to the control unit.

Follow the assembly steps in this P&P Guide.

**Note:** The solder diameter must match the ALE model purchased. Make sure the solder wire diameter is compatible with the wheels already installed in the ALE control unit.

*\*Solder reel is not included.*

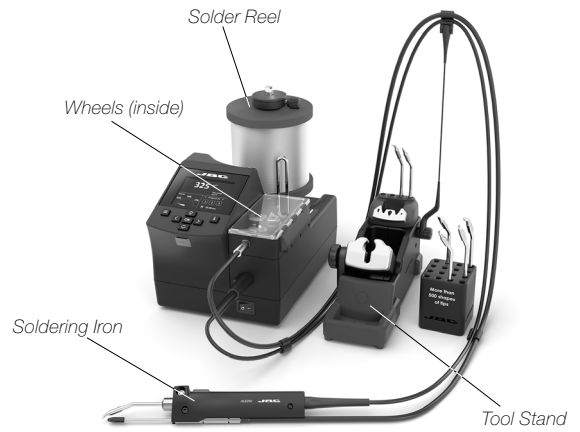

## Tools Needed

The required tools are located on the control unit.

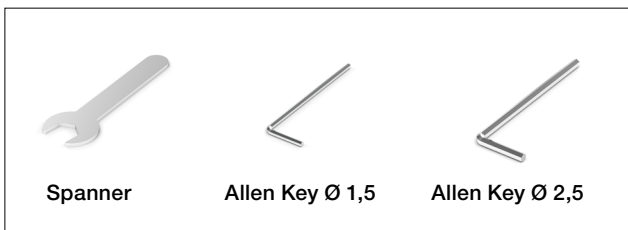

## Step 1 Solder Reel Assembly

Loosen the reel locking screw (1) and remove the reel locking from the axis (2).

Assemble the solder reel onto the axis (3).

Assemble the solder reel in such a way - when viewed from above - that the solder wire unwinds on the dispensing mechanism side (4).

Then pass the solder wire through the wire guidance (5).

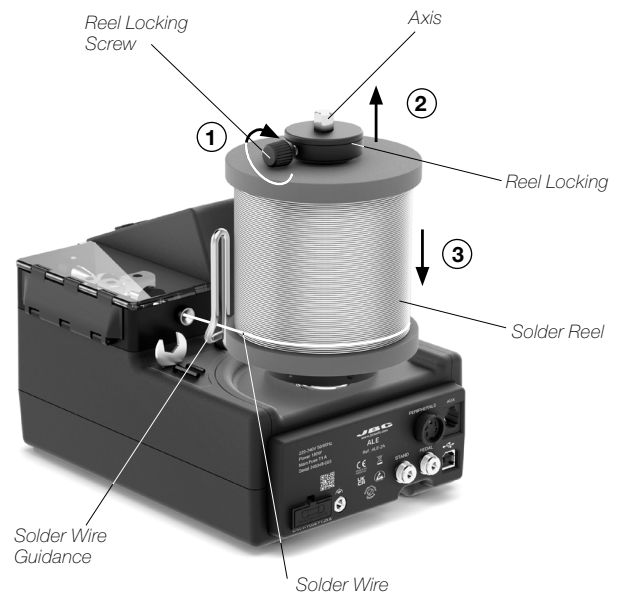
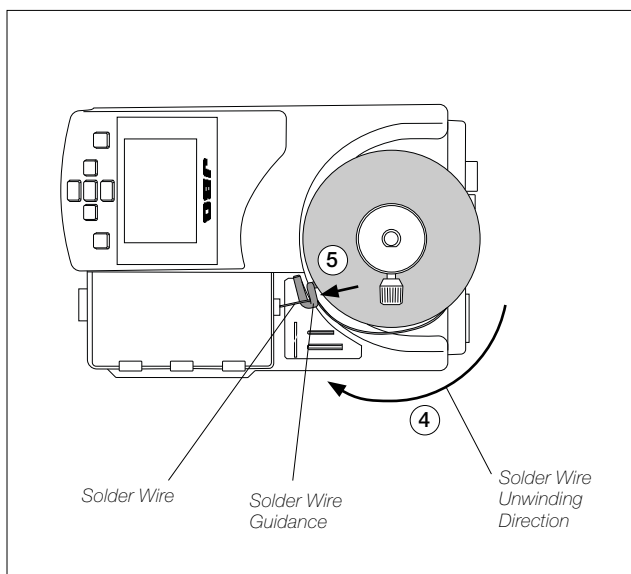

Watch the product assembly video



## Step 2 Reel Locking Assembly

To assemble the reel locking, its conical side must be pointing downwards (1).

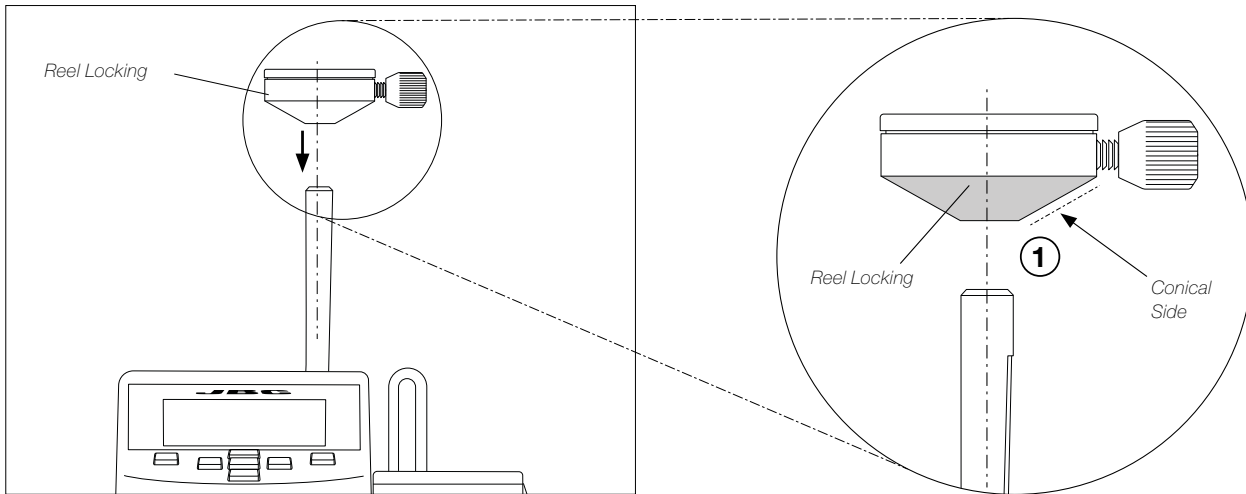

Align the flat side of the axis (2) with the inner flat side of the reel locking (3).

Make sure that the reel locking screw is slightly backed out and does not collide with the axis.

Reassemble the reel locking to the axis (4).

**Note:** To prevent the solder reel from spinning freely or binding, gently press the reel locking down, but only enough to allow the solder reel to rotate freely, before tightening the reel locking screw (5).

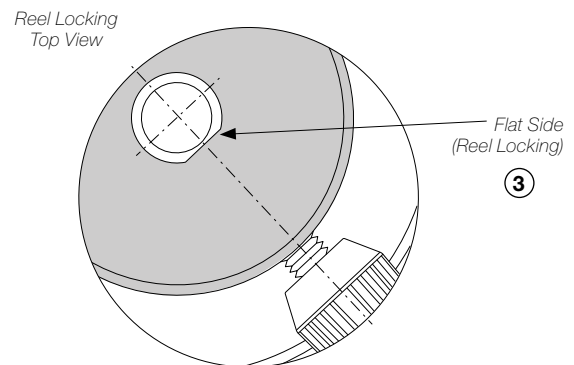
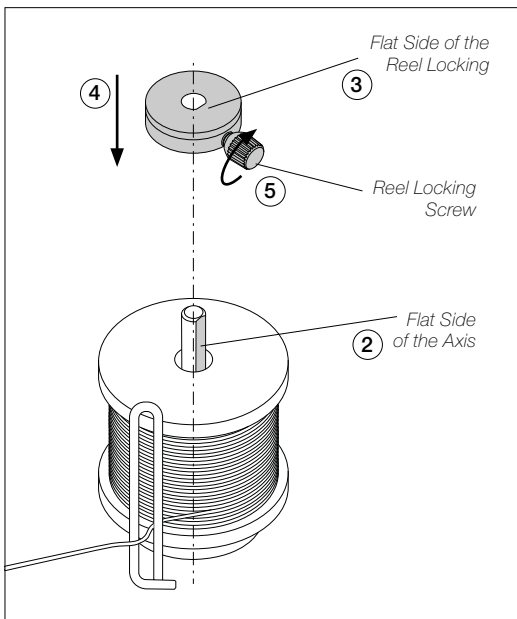

## Step 3 Cartridge Assembly

⚠ For a safe cartridge assembly/change, make sure that the tool is unplugged and the cartridge has cooled down.

Loosen the cartridge set screw (1) and insert the cartridge up to its mark (2). **Important:** It is essential to insert the cartridge completely for a good connection.

Adjust the tip direction (3) and tighten the cartridge set screw (1).

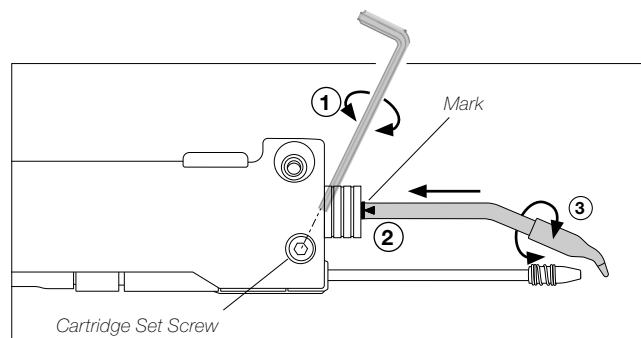

## Step 4 Guide Tube Set Assembly

Open the guide tube set screw (1) and insert the guide tube set.

Adjust the guide tube length (2). Leave a gap of 5 to 7 mm (0.197 to 0.276 in) between the tip and the outlet nozzle (3).

If necessary adjust the cartridge tip direction (4) to match the point where the wire will come out. To do this, open the cartridge set screw and tighten it when it is done (5).

Once the guide tube set position is adjusted tighten the guide tube set screw (1).

For a better handling use the clips (6) to band the guide tube and the tool cable together.

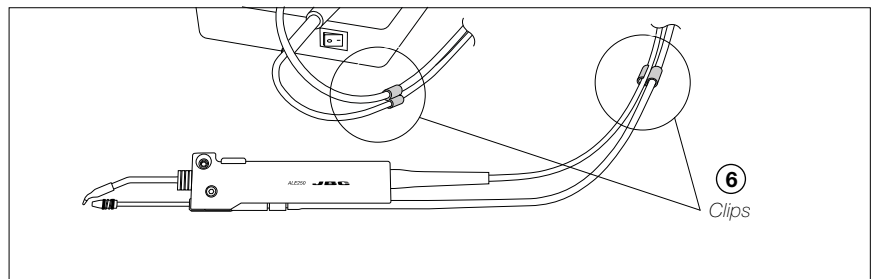
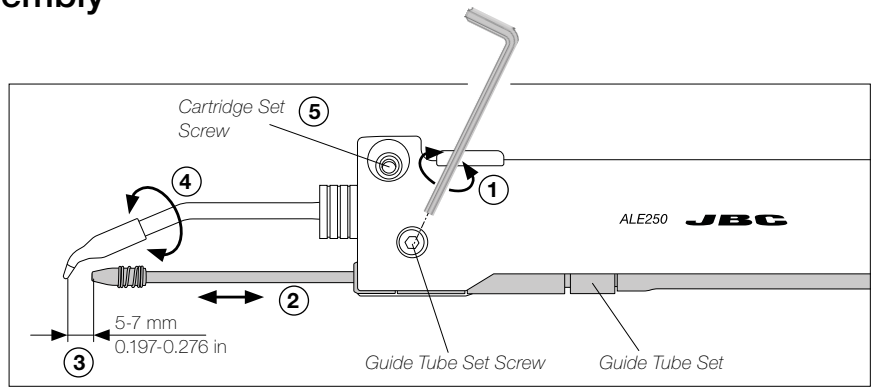

## Step 5 Tool Assembly

Connect the tool to the control unit following these steps:

Loosen the set screw (1), insert and push the guide nozzle until it stops (2) and tighten the set screw (1).

Then plug in the tool connector (3).

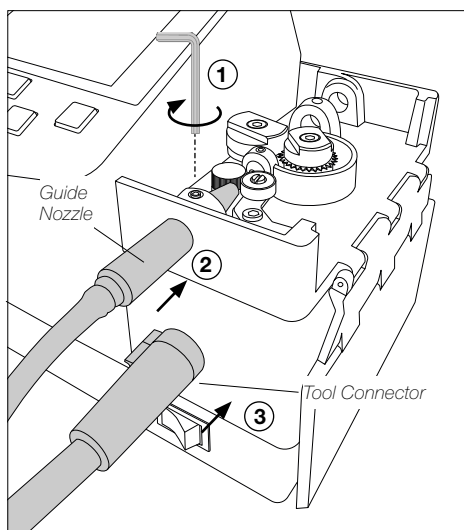

**ALE250**  
Automatic-Feed Soldering Iron



## Step 6 Stand, Pedal and Power Cord Installation

At the rear side of the control unit plug in the stand cable, the pedal cable and power cord.



## Step 7 Station Set Up

Hold up the tool or leave it in the tool holder and switch the station on. ⚠ Be careful, cartridge tip will get very hot.

### Important:

For correct operation, the diameter of the chosen solder wire must match that of the guide kit and its components (wheels, clamps and nozzles) assembled to the ALE. Guide kits for different wire diameters are available at [www.jbctools.com/solder-wire-guide-kit-product-2098.html](http://www.jbctools.com/solder-wire-guide-kit-product-2098.html)



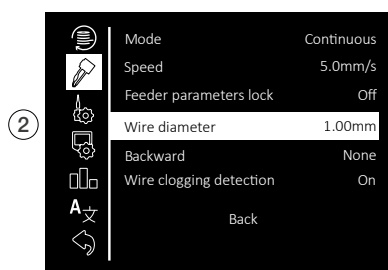
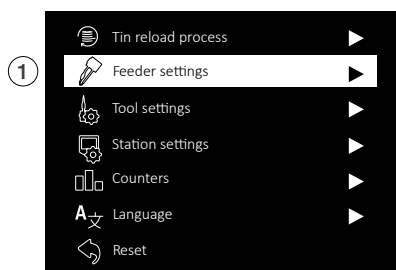

Change the wire diameter by accessing to main menu pressing , select "Feeder Settings" (1) and then "Wire Diameter" (2) to adjust the value to the current solder wire diameter.

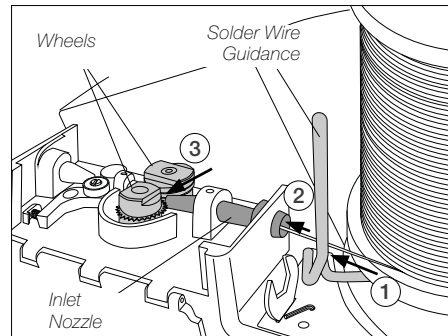

## Step 8 Solder Wire Loading

Make sure that the solder wire passes through the solder wire guidance (1). Introduce the solder wire into the inlet nozzle (2) until it reaches the wheels (3).



Select "Tin Reloaded Process" (1) and then press and hold  to feed the solder wire and advance until it comes out through the outlet nozzle.

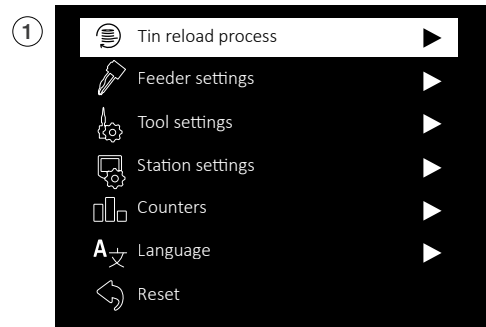

If needed, carefully push the wire until it gets locked in between the rotating wheels for the wire to start moving forward.

Keep  pressed and after a while the wire will advance faster.

Make sure the wire passes through the intermediate nozzle (4) and enters the guide tube (5).

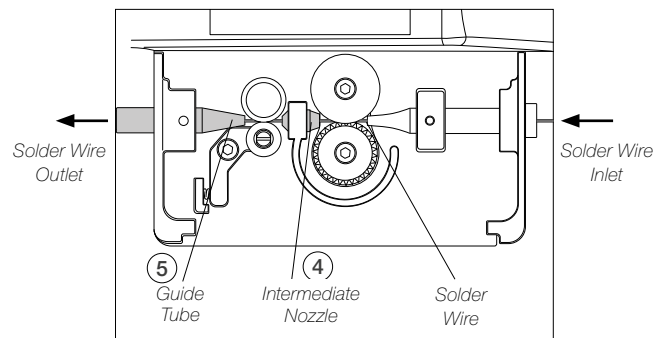

## Solder Wire Feeding

Forward the solder wire by pushing the dragging button (1) until the wire comes out of the tip (2).

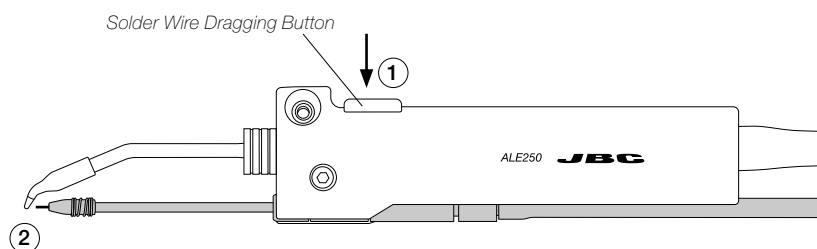

Alternatively solder wire can also be fed using the pedal P405. The pedal should be plugged in at the rear of the feeder control unit into the pedal connector.



## Step 9 Solder Wire Unloading

### With Solder Wire Perforation

To unload perforated solder wire that has already passed through the guide tube, cut the wire between the wire guidance and the inlet nozzle (1).

To extract the wire out of the tool and the guide tube, hold the tool on your hand and press  until the wire stops moving forward.

Grasp the wire coming out of the outlet nozzle with a pliers and pull from it until it is completely out.

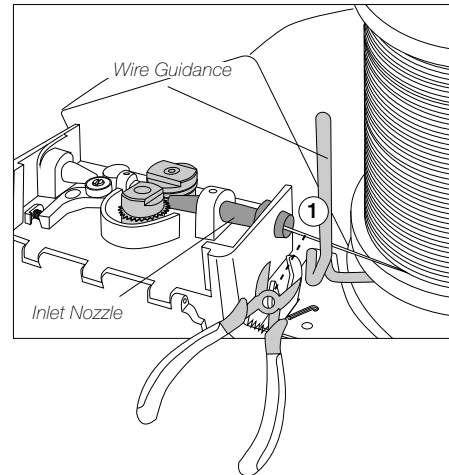

### Without Solder Wire Perforation

When using a kit without solder wire perforation, press  until the wire is completely wound to unload the solder wire. It is best to rotate the reel by hand as the wire is being pulled back in order to keep it neatly arranged on the reel.

Or, if preferred, proceed as described above for perforated solder wire unloading.

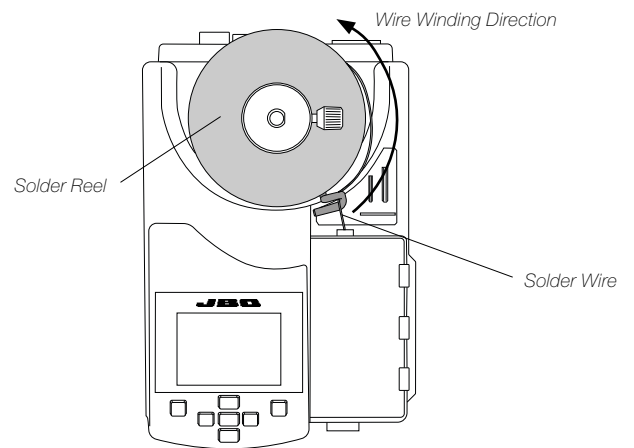

## Step 9 Control Process

### Feeder Setting Modes

Depending on the selected mode, different parameters are available for “Feeder Settings”.

Choose between “continuous”, “discontinuous” and “program” mode. Access to Main Menu by pressing , select “Feeder Settings” (1) and then “Mode” (2). For mor details see ALE control Unit Manual or JBC Web [www.jbctools.com/auto-feed-stations.html](http://www.jbctools.com/auto-feed-stations.html)

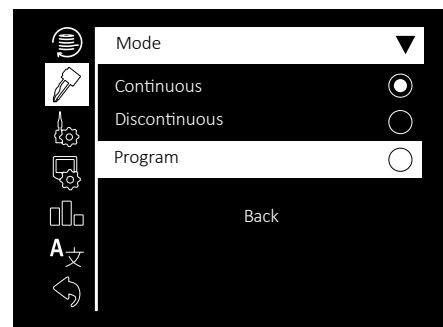
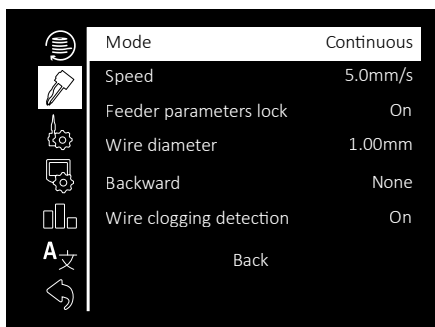

For more details see ALE control unit instruction manual, download at [www.jbctools.com/ale-product-2037.html](http://www.jbctools.com/ale-product-2037.html)



Access to ALE control unit product page

## Notes

---

---

---

---

---

---

---

---

---

---

---

---

---

---

---

---

---

---

---

---

---

---

---

---

---

---

---

---

---

---



# Specifications

## ALE

### Automatic-Feed Soldering Station

#### With Solder Wire Perforation

for wire Ø 0.8 mm /  
Ø 0.032 in

**ALE-908VA (100 V)**  
**ALE-108VA (120 V)**  
**ALE-208VA (230 V)**

for wire Ø 1.0 mm /  
Ø 0.040 in

**ALE-910VA (100 V)**  
**ALE-110VA (120 V)**  
**ALE-210VA (230 V)**

for wire Ø 1.2 mm /  
Ø 0.047 in

**ALE-912VA (100 V)**  
**ALE-112VA (120 V)**  
**ALE-212VA (230 V)**

for wire Ø 1.5 mm /  
Ø 0.060 in

**ALE-915VA (100 V)**  
**ALE-115VA (120 V)**  
**ALE-215VA (230 V)**

for wire Ø 1.6 mm /  
Ø 0.063 in

**ALE-916VA (100 V)**  
**ALE-116VA (120 V)**  
**ALE-216VA (230 V)**

#### Without Solder Wire Perforation

for wire Ø 0.38 - 0.4 mm /  
Ø 0.015 - 0.016 in

**ALE-904A (100 V)**  
**ALE-104A (120 V)**  
**ALE-204A (230 V)**

for wire Ø 0.46 - 0.56 mm /  
Ø 0.018 - 0.022 in

**ALE-905A (100 V)**  
**ALE-105A (120 V)**  
**ALE-205A (230 V)**

for wire Ø 0.6 - 0.64 mm /  
Ø 0.023 - 0.025 in

**ALE-906A (100 V)**  
**ALE-106A (120 V)**  
**ALE-206A (230 V)**

for wire Ø 0.7 - 0.78 mm /  
Ø 0.028 - 0.031 in

**ALE-907A (100 V)**  
**ALE-107A (120 V)**  
**ALE-207A (230 V)**

for wire Ø 0.80 - 0.82 mm /  
Ø 0.032 - 0.033 in

**ALE-908A (100 V)**  
**ALE-108A (120 V)**  
**ALE-208A (230 V)**

for wire Ø 0.90 - 1.10 mm /  
Ø 0.036 - 0.044 in

**ALE-910A (100 V)**  
**ALE-110A (120 V)**  
**ALE-210A (230 V)**

for wire Ø 1.14 - 1.27 mm /  
Ø 0.045 - 0.051 in

**ALE-912A (100 V)**  
**ALE-112A (120 V)**  
**ALE-212A (230 V)**

for wire Ø 1.5 - 1.57 mm /  
Ø 0.06 - 0.062 in

**ALE-915A (100 V)**  
**ALE-115A (120 V)**  
**ALE-215A (230 V)**

for wire Ø 1.6 - 1.63 mm /  
Ø 0.063 - 0.065 in

**ALE-916A (100 V)**  
**ALE-116A (120 V)**  
**ALE-216A (230 V)**

for wire Ø 1.8 mm /  
Ø 0.073 in

**ALE-918A (100 V)**  
**ALE-118A (120 V)**  
**ALE-218A (230 V)**

#### For all ALE Stations:

- Package Dimensions / Weight:  
(L x W x H)

545 x 345 x 275 mm / 6.72 Kg  
21.46 x 13.58 x 10.83 in / 14,82 lb

Complies with CE standards.  
ESD safe.

# JBC

## Warranty

Get 2 year JBC warranty by registering here:  
<https://www.jbctools.com/productregistration/>  
within 30 days of purchase.



This product should not be thrown in the garbage.

In accordance with the European directive 2012/19/EU, electronic equipment at the end of its life must be collected and returned to an authorized recycling facility.