

JBC

www.jbctools.com

INSTRUCTION MANUAL



RHT

Articulated Table Mounted Hand Rest

This manual corresponds to the following reference:

RHT-A

Packing List

The following items are included:



Articulated Hand Rest Arm 1 unit



Flange 1 unit



Shaft 1 unit



Flange Nut 3 units
DIN 934 M6 zinc-plated



Allen Key 1 unit
3mm - angled



Flange Screw 3 units
DIN 912 M6x50 stainless steel



Flange Washer 3 units
DIN 125 6.4 stainless steel



Height Adj. Flange 1 unit



Allen Screw..... 1 unit
DIN 913 M6x8 black-plated
Ref. 0017057

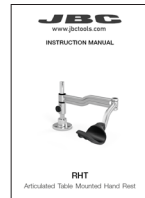

Manual..... 1 unit
Ref. 0033312

Features

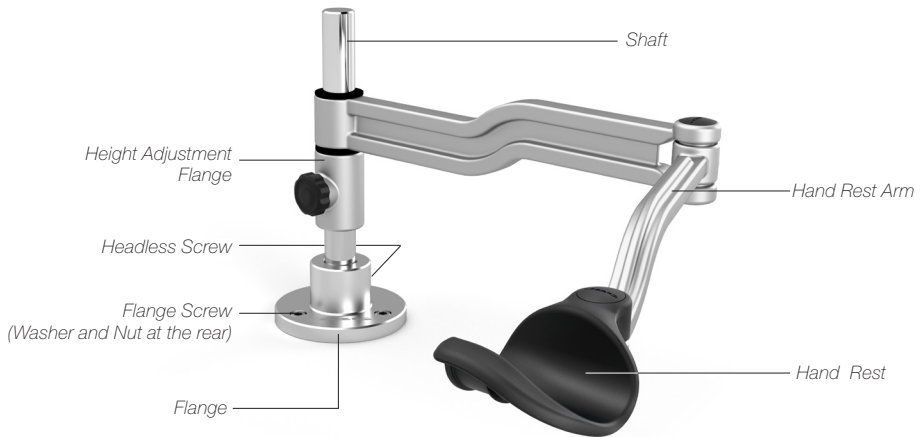

Assembly

Fixing the Flange

Fix the flange on your work table with the supplied screws, nuts and washers.

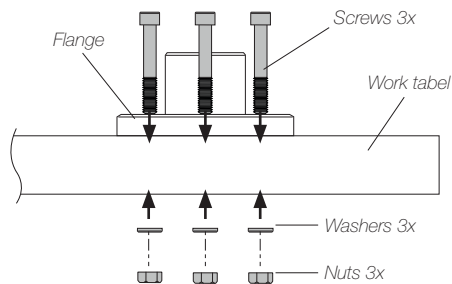

Assembly

Setting up Articulated Hand Rest

Fit the shaft into the flange bushing (1) and tighten the headless screw at the rear side (2). Then assemble first the height adjustment flange (3) and finally the hand rest arm (4) onto the shaft.

The hand rest arm position should be like shown in the image. The right hand rest is marked at its bottom side with the letter "R".

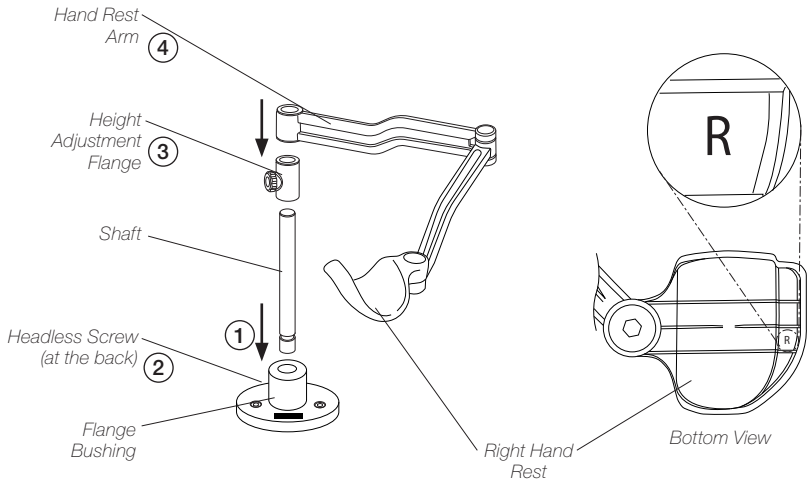

Height Adjustment

According to your work needs the articulated hand rest allows adjustment for different heights through the vertical axis.

Slide the hand rest arm to the appropriate height (1) and secure it by tightening the flange knob (2) to guarantee stability.

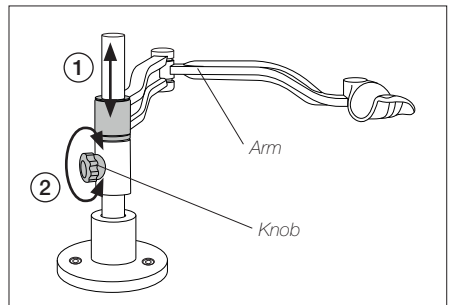

Work Position Adjustment

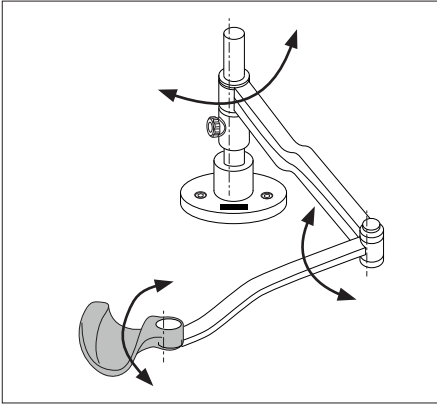

RHT Articulated Hand Rest allows adjustment for different positions according to your work needs.

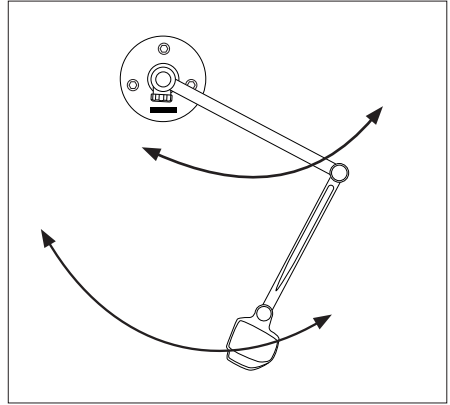

The articulated arm covers the entire working area.

Hand Position

The correct position of the hands for working is shown in the following images:

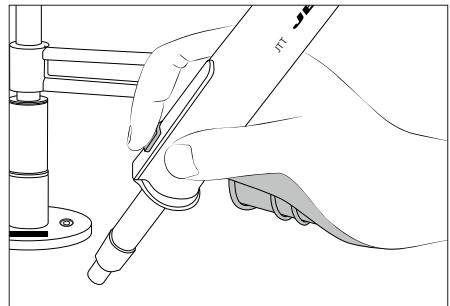
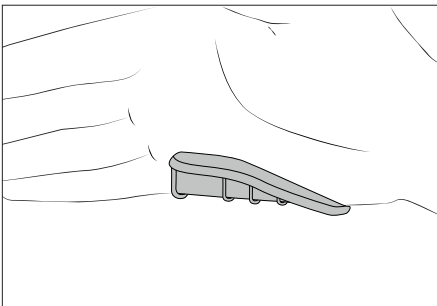

Accessories*

If a second hand rest is needed, Articulated Left Hand Rest HRL is available. HRL also allows adjustment for different positions.

HRL
Articulated Left Hand Rest

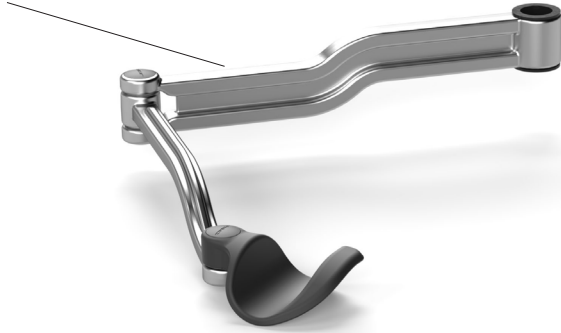

In the case of using both left and right arms, assemble both as shown in the illustration according to the letters on the back of the hand rest, to keep the hand supports at the same level. The right hand rest should be assembled below the left hand rest.

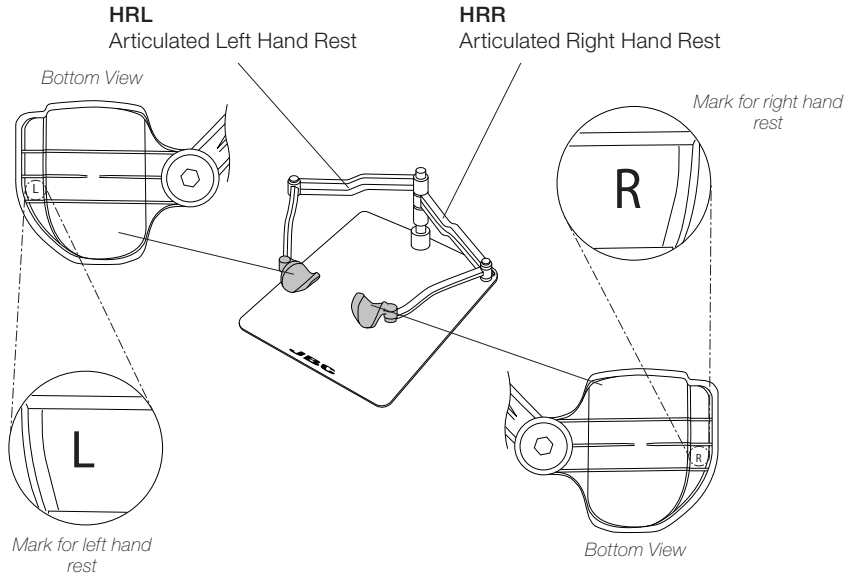

* Not included, sold separately.

Compatible JBC Articles*

HRR and HRL can be combined with:

RWT Adjustable Rework Arm,

RWS Adjustable Rework Arm for PHSE and

RWB Adjustable Rework Arm for PHBE.

Assemble first the height adjustment flange (1), then the HRR (2) and afterward the HRL (3). Assemble the second height adjustment flange (4) and finally the RWT (5).

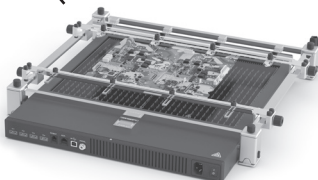
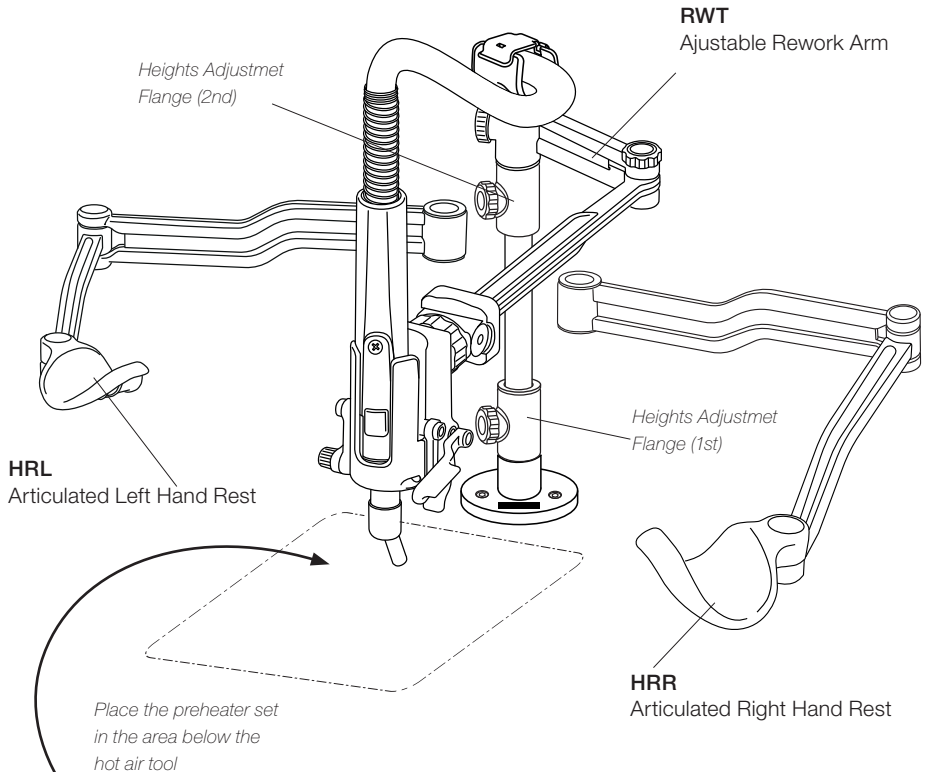

4 different sizes for PCB Supports are available:

- **PHNS** Support for PCBs up to 11x7 cm / 4x3"
- **PHSS** Support for PCBs up to 13x13 cm / 5x5"
- **PHBS** Support for PCBs up to 36x28 cm / 14x11"
- **PHXLS** Support for PCBs up to 51x61 cm / 20x24"

* Not included, sold separately.

Maintenance

- Check periodically that the RHT is clean, especially the sliding parts and the shaft.
- Use a damp cloth when cleaning. Alcohol can only be used to clean the metal parts.
- Replace any defective damaged parts. Use original JBC spare parts only.
- Repairs should only be performed by a JBC authorized technical service.

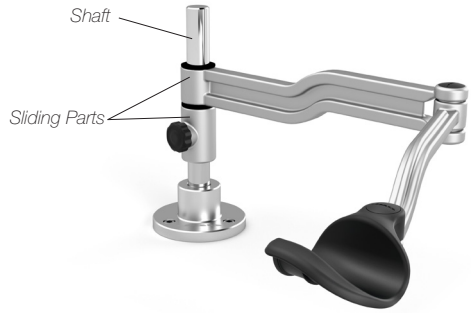

 **Do not leave the RHT over the preheater when it is in operation.**

Safety

 **It is imperative to follow safety guidelines to prevent electric shock, injury, fire or explosions.**

- Do not use the equipment for any purpose other than PCB rework. Incorrect use may cause a fire.
- The temperature of accessible surfaces may remain high after the unit is turned off. Handle with care.
- Be careful with the fumes produced when soldering.
- Keep your workplace clean and tidy. Wear appropriate protection glasses and gloves when working to avoid personal harm.
- Do not leave up the arms directly above heat surfaces.
- Utmost care must be taken with liquid tin waste which can cause burns.
- This appliance can be used by children over the age of eight as well as persons with reduced physical, sensory or mental capabilities or lacking experience provided that they have been given adequate supervision or instruction concerning the use of the appliance and understand the hazards involved. Children must not play with the appliance.
- Maintenance must not be carried out by children unless supervised.

Notes

Specifications

RHT

Articulated Table Mounted Hand Rest

Ref. RHT-A

- Height: 205 mm / 8.1 in
- Arm Length: 444.5 mm / 17.5 in
- Total Net Weight: 1.81 kg / 3.99 lb

- Package Dimension / Weight: 474 x 368 x 195 mm / 2.62 kg
(L x W x H) 18.66 x 14.49 x 7.68 in / 5.78 lb

Complies with CE standards
ESD Safe

JBC

Warranty

JBC's 2 year warranty covers this equipment against all manufacturing defects, including the replacement of defective parts and labour.

Warranty does not cover product wear or misuse.

In order for the warranty to be valid, equipment must be returned, postage paid, to the dealer where it was purchased.



This product should not be thrown in the garbage.

In accordance with the European directive 2012/19/EU, electronic equipment at the end of its life must be collected and returned to an authorized recycling facility.



www.jbctools.com