

JBC

www.jbctools.com

Product
website



INSTRUCTION MANUAL



DME

4-Tool Control Unit

This manual corresponds to the following references:

DME-9B (85-265 V) - Power cord ref. 0024077 (100 V)

DME-1B (85-265 V) - Power cord ref. 0023717 (120 V)

DME-2B (85-265 V) - Power cord ref. 0024080 (230 V)

Packing List

The following items are included:



4-Tool Control Unit 1 unit

Power Cord 1 unit
Ref. 0024077 (100 V)
0023717 (120 V)
0024080 (230 V)

Manual 1 unit
Ref. 0036024

Features

DME works simultaneously with **up to** 4 tools, 1 peripheral module and 1 pedal.

Note: A peripheral module is needed when working with a desoldering iron or a nitrogen handle. It is possible to connect an additional pedal to the peripheral module.



Connection Example

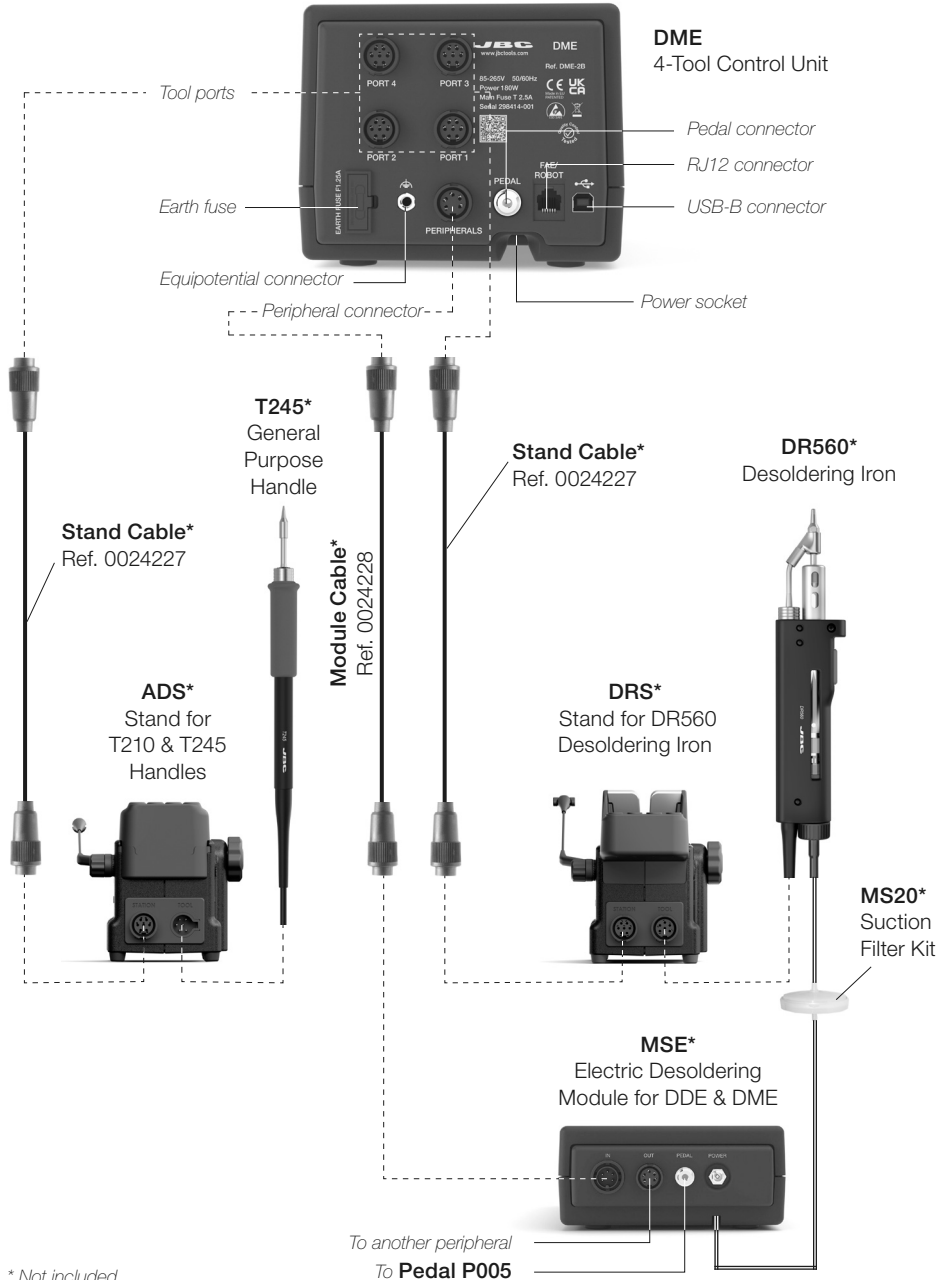

* Not included

Compatibility

Combine the equipment that best suits your soldering or desoldering needs.

Devices marked with an ○ mean that the pedal cannot be connected directly to this control unit. A module must be used, and the pedal must be connected to that module.

Modular System				Modules				Pedals			
Control Unit	Stand	Tool	Cartridge Range	MSE-A	MSE-B	MVE	MNE	P005	P305	P405	
DME	ADS	T210	C210						●		
		T245	C245						●		
		T470							●		
	DNS	T210N	C210				●	○	●	○	
		T245N	C245				●	○	●	○	
	APS	AP250	C250						●		
	AMS	AM120	C120							●	
		PA120								●	
	ATS	AT420	C420						●		
	HTS	HT420								●	
	DSS	DS360	C360		●	●			○	●	○
	DRS	DR560	C560		●	●			○	●	○
	DTS	DT530	D530		●	●			○	●	○

Compatibility table valid for DME-B version of the control unit onwards. For more information on compatibility with previous versions, contact JBC Technical Support at www.jbctools.com/contact-us.html.

DME Work Screen

DME offers an intuitive user interface which provides quick access to station parameters.

Default PIN: 0105

The diagram illustrates the DME Work Screen interface. At the top, a **Status Bar** displays a speaker icon and the time **19:29**. The main display area shows a **Power Indicator** on the left, a large temperature reading of **350 °C** in the center, and a **Tool in use** image on the right. Below the temperature, a **Temp levels** section contains three buttons: **250**, **350** (highlighted), and **380**. A **Power 45%** indicator is shown at the bottom left of the screen, and **Port 1** is labeled at the bottom right. A central navigation pad includes a menu icon (three horizontal lines), an up arrow, a down arrow, left and right arrows, an **OK** button, and an information icon (i). The information icon is labeled **Station Information** and **Change Port**. Below the screen, five menu options are detailed: **Station** (Set the station parameters), **Tools** (Set the tool parameters), **Counters** (Display the hours worked in each cycle), **Language** (It is possible to choose the language from a list), and **Reset** (Restore station parameters to default values).

Troubleshooting

Station troubleshooting available on the product page at www.jbctools.com

Advanced Functionalities



Graphics

It provides detailed graphics of tip temperature and power delivery in real time during solder joint formation for analysis purposes. This helps you decide how to adjust your process or which tip to use to obtain the best quality soldering.



Profiles

Designed to avoid thermal shock when soldering Ceramic Chip components like MLCC, this new and unique feature allows controlling the heating rate to gradually increase the temperature of the component through all the phases of the soldering process. Up to 25 fully configurable soldering profiles can be stored.

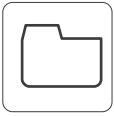

Files

Export graphics

Insert a USB flash drive into the USB-A connector to save your soldering process in csv format.



Update

Station update

Download the JBC Update File from www.jbctools.com/software.html Insert the USB flash drive with the file downloaded to the station.

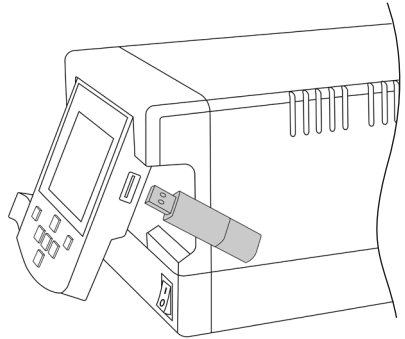

System Notifications

The following icons can be displayed on the screen's status bar.



USB flash drive is connected.



Station software update. Press INFO to start the process.



Station is controlled by a PC.



Warning. Press INFO for failure description.



Station is controlled by a robot downloaded to the station.



Error. Press INFO for failure description, the type of error and how to proceed.

Peripherals Set Up

Module Set Up

1. After connecting the module, enter the Peripherals Menu and select the port which you want to join with the module.
2. Select the module from the list of peripheral connections. Remember your first connection is denoted as “a”, the second being “b”, etc. (e.g. MS_a, MS_b, etc.).
3. Press Menu or Back to save changes.

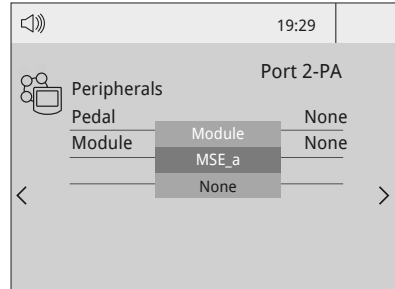

Pedal Set Up

1. Enter the **Peripherals** menu and **select the port** to which you want to link the pedal.

2. Select the pedal from the list (*Note that your first connection is denoted as “a”, the second being “b”, etc. (e.g. PD_a, PD_b, etc.).*)

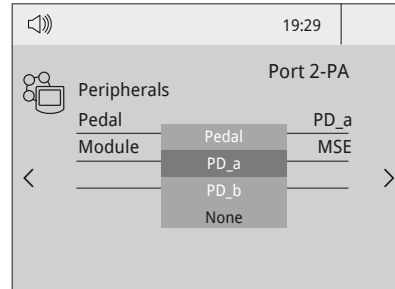
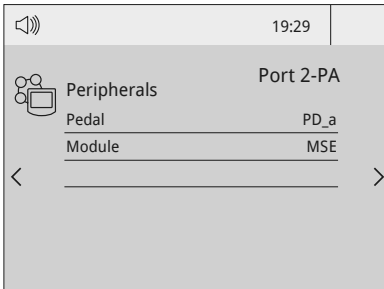

3. Set the pedal function according to your work needs:

Select how the pedal acts:
as **Sleep, Extractor** (hibernation) or
as a **module switch**.

Select the activating
mode of the pedal
(**pressed/released**)

Set the duration of the activation time when
pressing the pedal once*. For continuous
functioning keep the pedal pressed.

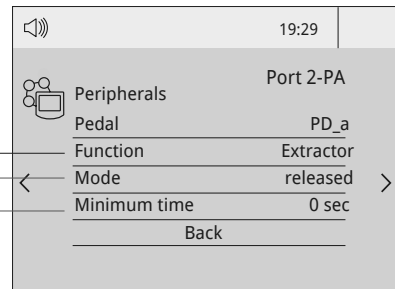

***Note:** The pedal function can be used in reverse. This means that holding the pedal down deactivates the function and releasing the pedal activates the function.

Peripherals Set Up - continuation

FAE Fume Extractor Set Up

This control unit can be connected to the fume extractor using an RJ12 cable. This way, the fume extractor automatically starts extraction when the soldering tool is in use.

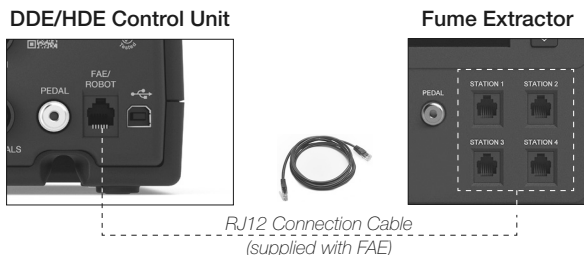

The connected fume extractor can be configured and controlled through the Peripherals (1) menu on the control unit.

Each control unit detects the fume extractor as "FAE_a" (2). The tool that should activate the fume extraction needs to be configured on the control unit main menu through the Tools menu (3).

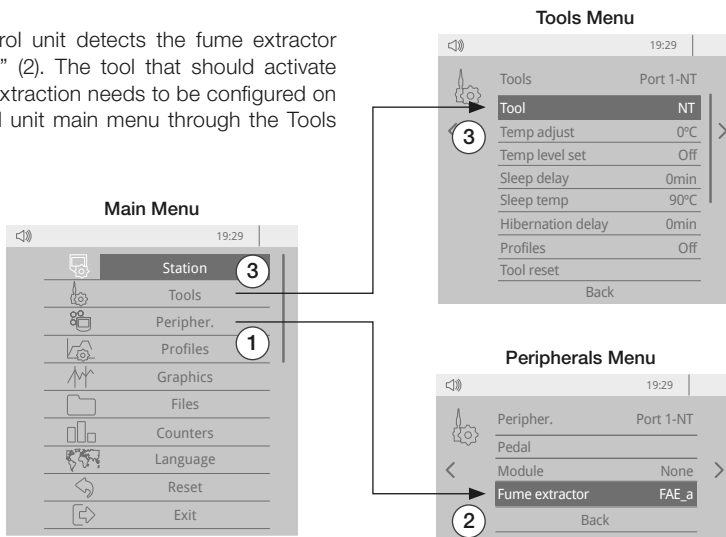

Connect up to 4 control units (connector FAE/ROBOT) to the fume extractor connectors (STATION 1, STATION 2, ...). Each tool connected to these control units can start and stop the fume extractor.

Operation

JBC's Most Efficient Soldering System

Our revolutionary technology is able to recover tip temperature extremely quickly. It means the user can work at a lower temperature and improve the soldering quality. The tip temperature is further reduced thanks to the Sleep and Hibernation modes which increase up to 5 times the life of the tip.

1. Work

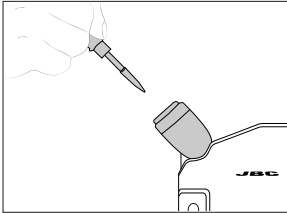

When the tool is lifted from the stand the tip will heat up to the selected Work temperature.

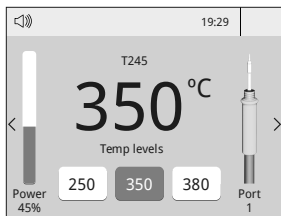

Tool Settings:
· *Work Temp.*

Change Work temperature from 90 to 450 °C.

⬆ / ⬇ steps of ± 5 °C / °F

Tool Settings:
· *Temp. Levels*

Press , select *Tool Settings* and activate the *Temp. Levels* option.

⬆ / ⬇ steps of ± 5 °C / °F.

2. Sleep

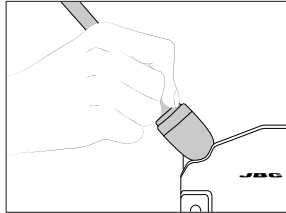

When the tool is in the stand, the temperature falls to the preset Sleep temperature.



Tool Settings:
· *Sleep*

Change Sleep temperature and set Sleep delay from 0 to 9 min or no Sleep.

3. Hibernation

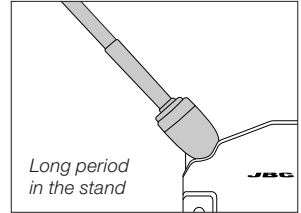

After longer periods of inactivity, the power is cut off and the tool cools down to room temperature.

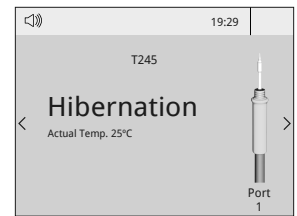

Tool Settings:
· *Hibernation*

Change Hibernation delay from 0 to 60 min or no Hibernation.

Maintenance

Before carrying out maintenance or storage, always allow the equipment to cool down.

- Clean the station display with a glass cleaner or a damp cloth.
- Use a damp cloth to clean the casing and the tool. Alcohol can only be used to clean the metal parts.
- Periodically check that the metal parts of the tool and stand are clean so that the station can detect the tool and establish its status.
- Maintain the tip surface clean and tinned prior to storage in order to avoid tip oxidation. Rusty and dirty surfaces reduce heat transfer to the solder joint.
- Periodically check all cables and tubes.
- Replace a blown fuse as follows:

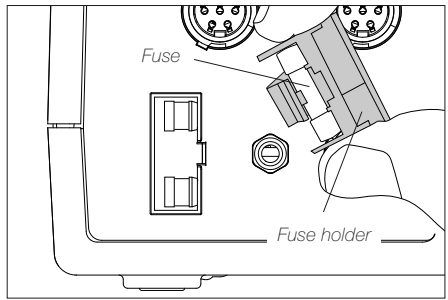
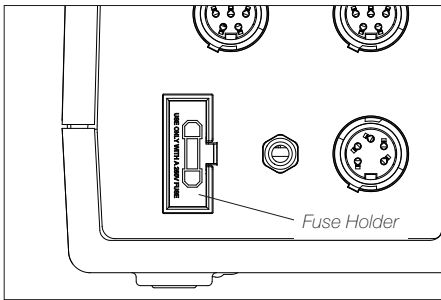

1. Pull off the fuse holder and remove the fuse. If necessary, use a tool to lever it off.

2. Insert the new fuse into the holder and return it to the station.

- Replace any defective or damaged pieces. Use original JBC spare parts only.
- Repairs should only be performed by a JBC authorized technical service.

Safety



It is imperative to follow safety guidelines to prevent electric shock, injury, fire or explosion.

- Do not use the units for any purpose other than soldering or rework. Incorrect use may cause a fire.
- The power cord must be plugged into approved bases. Be sure that it is properly grounded before use. When unplugging it, hold the plug, not the wire.
- Do not work on electrically live parts.
- The tool should be placed in the stand when not in use in order to activate the sleep mode. The soldering tip or nozzle, the metal part of the tool and the stand may still be hot even when the station is turned off. Handle with care, including when adjusting the stand position.
- Do not leave the appliance unattended when it is on.
- Do not cover the ventilation grills. Heat can cause inflammable products to ignite.
- Avoid flux coming into contact with skin or eyes to prevent irritation.
- Be careful with the fumes produced when soldering.
- Keep your workplace clean and tidy. Wear appropriate protection glasses and gloves when working to avoid personal harm.
- Utmost care must be taken with liquid tin waste which can cause burns.
- This appliance can be used by children over the age of eight and also people with reduced physical, sensory or mental capabilities or lack of experience provided that they have been given adequate supervision or instruction concerning the use of the appliance and understand the hazards involved. Children must not play with the appliance.
- Maintenance must not be carried out by children unless supervised.

Specifications

DME

4-Tool Control Unit

Ref. **DME-1B** 85 - 265 V 50/60 Hz. Input fuse: T-2.5 A. Output: 23.5 V.

Ref. **DME-2B** 85 - 265 V 50/60 Hz. Input fuse: T-2.5 A. Output: 23.5 V.

Ref. **DME-9B** 85 - 265 V 50/60 Hz. Input fuse: T-2.5 A. Output: 23.5 V.

- Nominal Power: 200 W
- Peak Power (Tool): 150 W per tool (with more than one tool in use simultaneously, peak power is limited)
- Selectable Temperature: 90 - 450 °C / 190 - 840 °F
- Idle Temp. Stability (still air): ± 1.5 °C / ± 3 °F meets and exceeds IPC J-STD-001F
- Temp. Accuracy: ± 3 % (using reference cartridge)
- Temp. Adjustment: ± 50 °C / ± 90 °F through the station's settings menu
- Tip to Ground Voltage/Resistance: Meets and exceeds ANSI/ESD S20.20 and IPC J-STD-001F
- Ambient Operating Temp.: 10 - 40 °C / 50 - 104 °F
- Connections:
 - USB-A: Firmware Update, Graphics and Profiles
 - USB-B: PC Communication
 - RJ12: Fume Extractor/Peripherals/Robot
- Control Unit Dimensions: 232 x 148 x 120 mm / 9.13 x 5.83 x 4.72 in (L x W x H)
- Net Weight: 1.30 kg / 2.85 lb
- Total Package Dimensions/Weight: 258 x 328 x 208 mm / 2.49 kg (L x W x H) 10.16 x 12.91 x 8.19 in / 5.48 lb

Complies with CE standards.
ESD safe.

JBC

Warranty

JBC's 2 year warranty covers this equipment against all manufacturing defects, including the replacement of defective parts and labor.

Warranty does not cover product wear or misuse.

In order for the warranty to be valid, equipment must be returned, postage paid, to the dealer where it was purchased.

Get 1 extra year JBC warranty by registering here:
<https://www.jbctools.com/productregistration/>
within 30 days of purchase.

If you register, you will receive e-mail notifications about new software updates for your registered product.



This product should not be thrown in the garbage.

In accordance with the European directive 2012/19/EU, electronic equipment at the end of its life must be collected and returned to an authorized recycling facility.

CE EAC UK
CA

www.jbctools.com

0036024-270226