

JBC

www.jbctools.com



AL250

SOLDERING IRON

AL250 / SOLDERING IRON

**AL250-B
SOLDERING IRON**



MANUAL



INSTALLATION

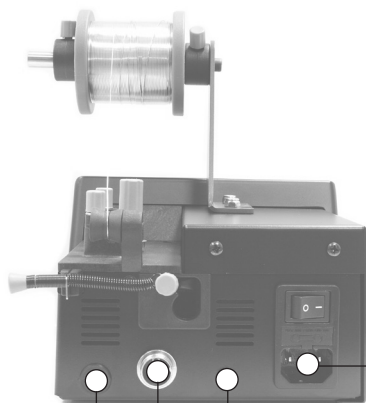

**AL-2A / AL-1A
AL-9A / AL-2AA
SOLDER FEED
STATION**

*Power cord
socket*

*Equipotential
connection*

0964551
*Pedal
(optional)*



**AL-SC
STAND**

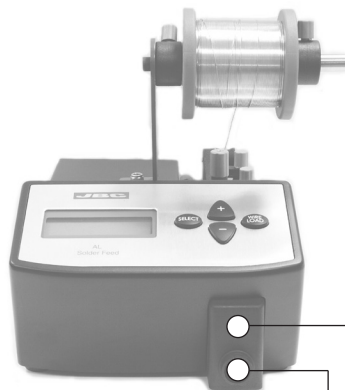

**AL250-B
SOLDERING IRON**



CHANGING THE HANDPIECE'S CARTRIDGE

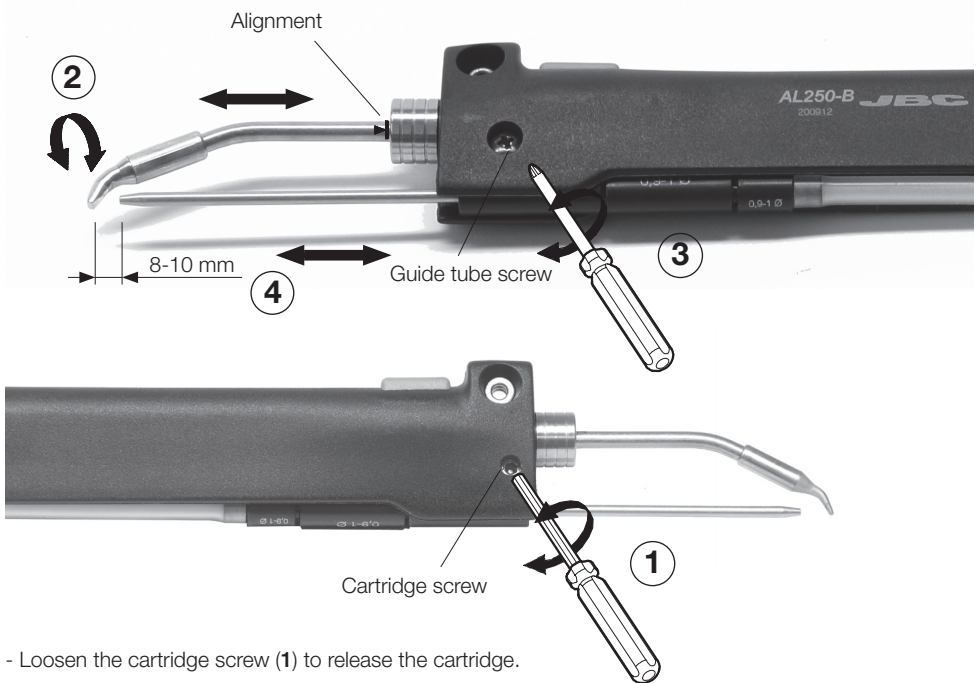

- Loosen the cartridge screw (1) to release the cartridge.
- Place the cartridge in the solder feed handle.
- Important:** It is essential to insert the cartridge till the end for a good connection. Use the mark  as reference.
- Align the tip of the cartridge with the solder guide tube (2). Tighten the cartridge screw (1).
- You must leave a gap of 8-10 mm between cartridge tip and the end of the guide tube (4). Loosen the guide screw (3). Adjust the guide tube and tighten screw (3).

ACCESSORIES

F4468
FUME EXTRACTOR



AL-IA
HANDS-FREE SOLDERING
ARM AND FUME
EXTRACTOR



C250 CARTRIDGE RANGE

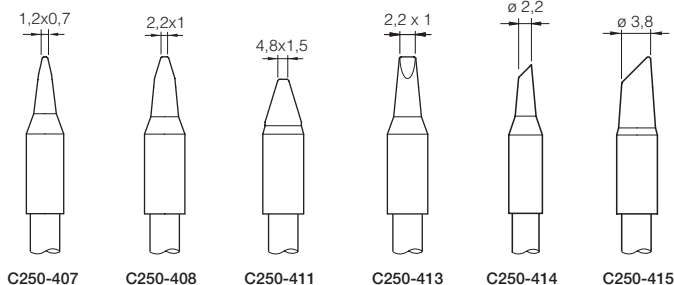
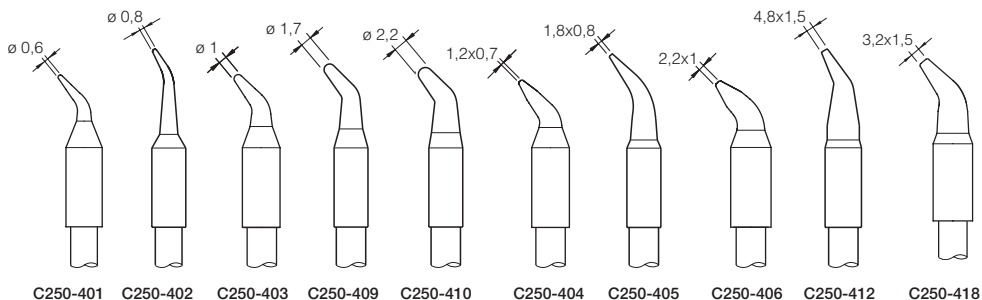

Consult our wide range of cartridges with more than 250 references in www.jbctools.com

For special cartridges contact with our distributor.

All the cartridges shown are actual size.



This product should not be thrown in the garbage.

JBC

WARRANTY

JBC's 2 years warranty guarantees this equipment against all manufacturing defects, covering the replacement of defective parts and all necessary labour.

Warranty does not cover product wear due to use or mis-use.

In order for the warranty to be valid, equipment must be returned, postage paid, to the dealer where it was purchased enclosing this fully filled in, sheet.

SERIAL N°

STAMP OF DEALER

DATE OF PURCHASE

www.jbctools.com