

JBC

www.jbctools.com

Product
webpage



INSTRUCTION MANUAL



SF

Automatic Solder-Wire Feeder Station

This manual corresponds to the following references:

SF-110VB (110-120V) with Guide Kit \varnothing 1mm

SF-210VB (230V) with Guide Kit \varnothing 1mm

Packing List

The following items are included:



Automatic Solder-Wire Feeder Control Unit 1 unit



Auto Solder-Wire Handle 1 unit
Ref. SF280



Guide Kit 1 unit
Ref. GSF10V-B
already assembled

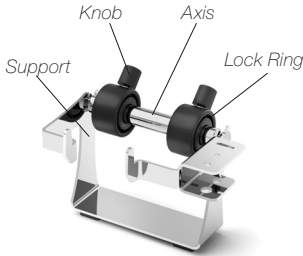

Reel Support 1 unit
Ref. 0018624

includes:

- Ref. 0019301 (x1) - Support
- 0018033 (x1) - Axis
- 0003412 (x2) - Lock Ring
- 0014427 (x2) - Knob

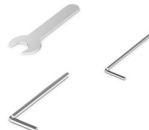

Key Set for SF 1 unit
Ref. 0019341

includes:

- Ref. 0012574 (x1) - Allen key \varnothing 2,5
- 0017631 (x1) - Spanner
- 0741610 (x1) - Allen key \varnothing 1,5



Power cable 1 unit
Ref. 0023715 (100V/120V)
0023714 (230V)



Manual 1 unit
Ref. 0028008

Features and Connections

Automatic Solder-Wire Feeder Control Unit

SF280 Automatic Solder-Wire Handle



Tool Assembly

Connect the tool to the control unit following this steps:

Insert and push the guide nozzle until the end (1) and tighten the screw (2).

Connect the jack (3).

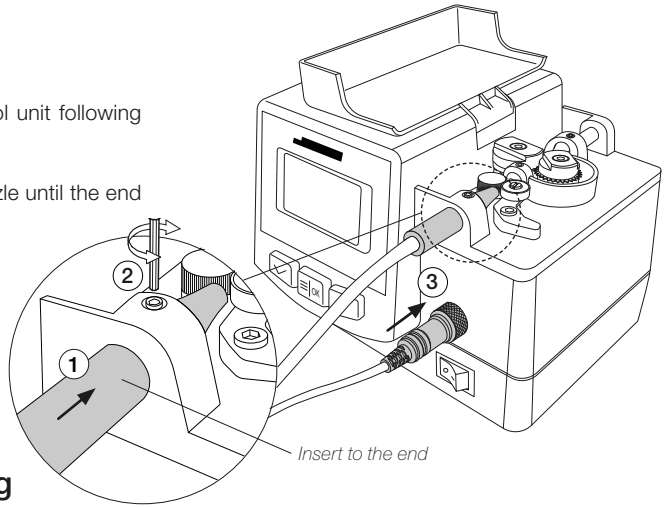

Solder-Wire Loading

Put the solder reel into its support (1).

Introduce the solder wire into the inlet nozzle (2) until it reaches the wheels (3).

Use the *Tin Reload Process* in the *Main Menu* (4).

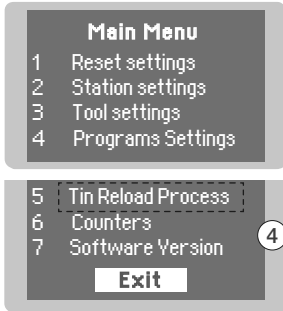

The Reload Process screen opens. Press to start the process.

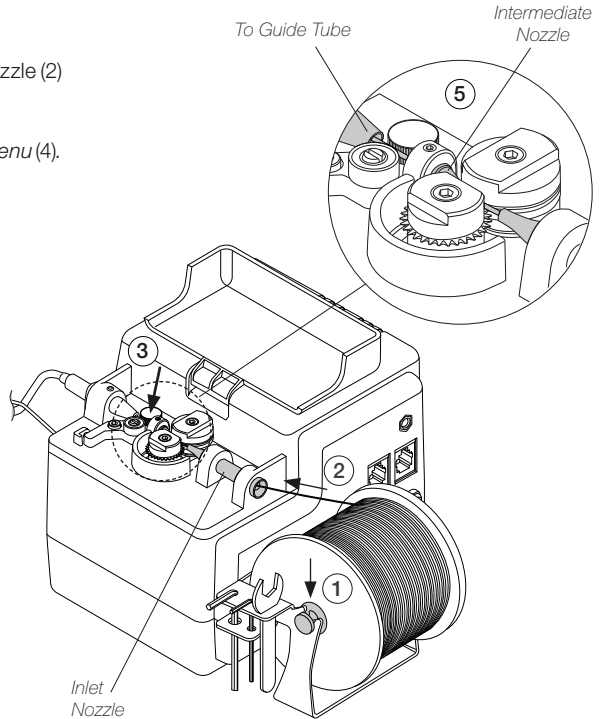
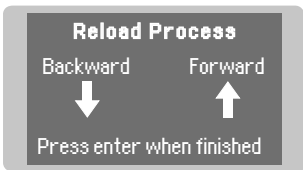

Make sure the wire passes through the Intermediate Nozzle and enters into the Guide Tube (5).

Solder-Wire Unloading

With Solder Wire Perforation

To unload solder wire with perforation that has already passed through the guide tube, cut the wire between the solder reel and the inlet nozzle (1).

To extract the wire out of the tube, hold the tool on your hand and press until the wire stops moving forward.

Grasp the wire coming out of the outlet nozzle with a pliers and pull from it until it is completely out.

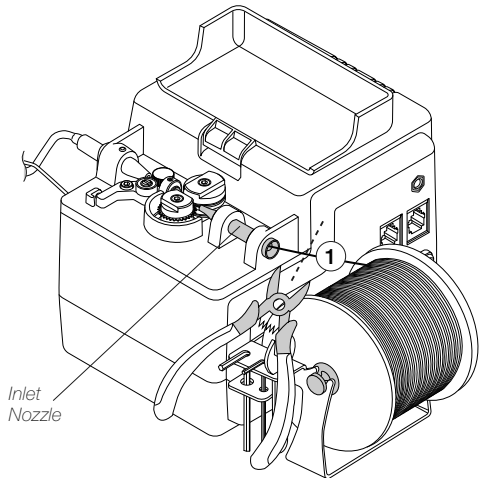

With Solder Wire Perforation

When using a guide kit without solder wire perforation, press until the wire is completely wound on the solder reel to unload the solder wire. It is best to rotate the reel by hand as the wire is being pulled back in order to keep it neatly arranged on the reel.

Or, if preferred, proceed as described before for perforated solder wire unloading.

Changing Guide Kits

Changing Wheels and Blade

For this operation, disconnect the device from the mains. Disconnect the tool from the control unit and open its cover.

Use the Allen key and the spanner, provided with the station. First disassemble the guide tube (6), the support and traction wheels, or the guide wheel, the blade and its clamp (4)+(5). Then, disassemble the nozzles (2)+(3). Disassemble the counter wheel (1).

Assembly with Solder Wire Perforation:

Assemble the counter wheel (1).

Insert the intermediate nozzle (2) until its collar rests against the housing and tighten the screw.

Assemble the inlet nozzle (3).

Assemble the guide wheel* (4) and tighten the screw.

Assemble the blade first, then mount the blade clamp (5) onto the same axis and tighten the screw. **Caution:** handle the blade carefully to avoid injury.

Insert the guide set (6).

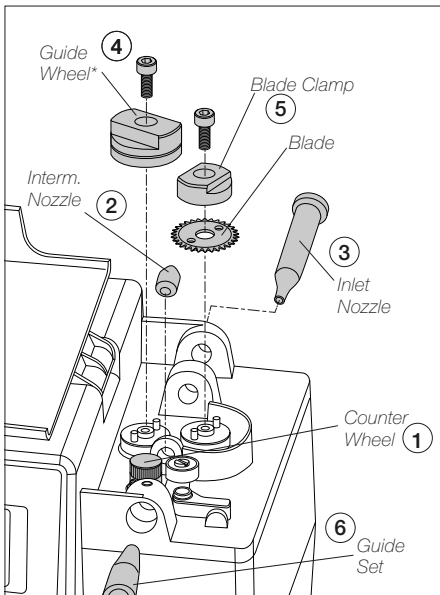

Assembly without Solder Wire Perforation:

Assemble the counter wheel (1).

Insert the intermediate nozzle (2) until its collar rests against the housing and tighten the screw.

Assemble the inlet nozzle (3).

Assemble the support wheel* (4) onto the axis and tighten the screw.

Assemble the traction wheel (5) and tighten the screw.

Insert the guide set (6).

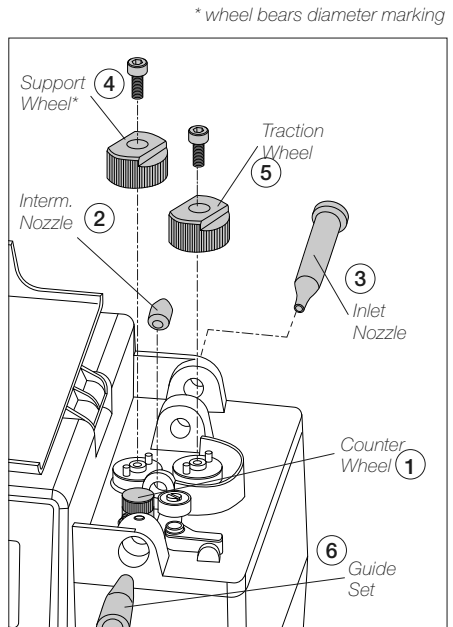

Outlet Nozzle Replacement

Flux can cause clogging at the outlet nozzle of the guide tube set and it can be necessary to replace the worn or clogged outlet nozzle.

Note: There is a nozzle size for each soldering wire diameter. The use of the nozzle is necessary as its inner diameter is adjusted to the solder wire diameter and guides the wire with greater precision.

To replace the outlet nozzle, follow these steps:

First, unload any remaining solder wire that might still be inside the guide tube (see page 5) and then unplug the tool. Unscrew the spring inwards (2), following the downward direction of the spring.



Once the outlet nozzle is released from the spring, pull the outlet nozzle out (2) and then remove the spring (3).

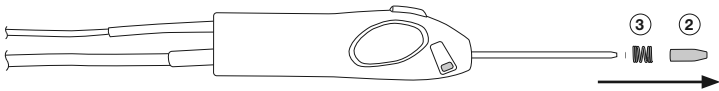

Place the new outlet nozzle onto the guide tube set (4) and then screw back the spring onto it to fix the outlet nozzle onto the guide tube (5).

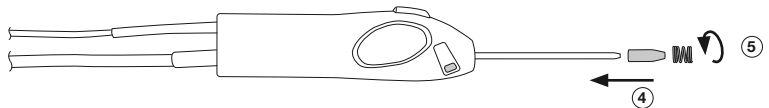

Guide Tube Replacement

To replace the guide tube, follow the outlet replacement steps until reaching no. 3. Once both the outlet nozzle and the spring are removed, open the guide clamp knob (6) and remove the guide tube (7).

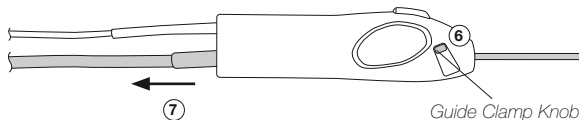

Insert the new guide tube into the tool, close the guide clamp knob to fix it in place and follow steps 4 and 5 to fix the outlet nozzle.

Enter "Tool Settings" at the SF control unit main menu and select the proper wire diameter to complete the process.



Control Process

Work Screen

Choose between continuous, discontinuous and program mode:



Program Mode

With the SF you can define up to 35 dynamic programs. In each one you can configure up to 3 steps with different wire length and dispensing speed.

Execute them sequentially and cyclically with the 'Edit Concatenation List' option.

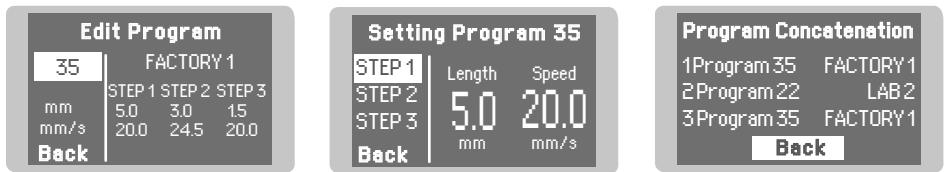

Troubleshooting

Station troubleshooting available on the product page on www.jbctools.com.

Control Process

Menu Screen

Default PIN: 0105

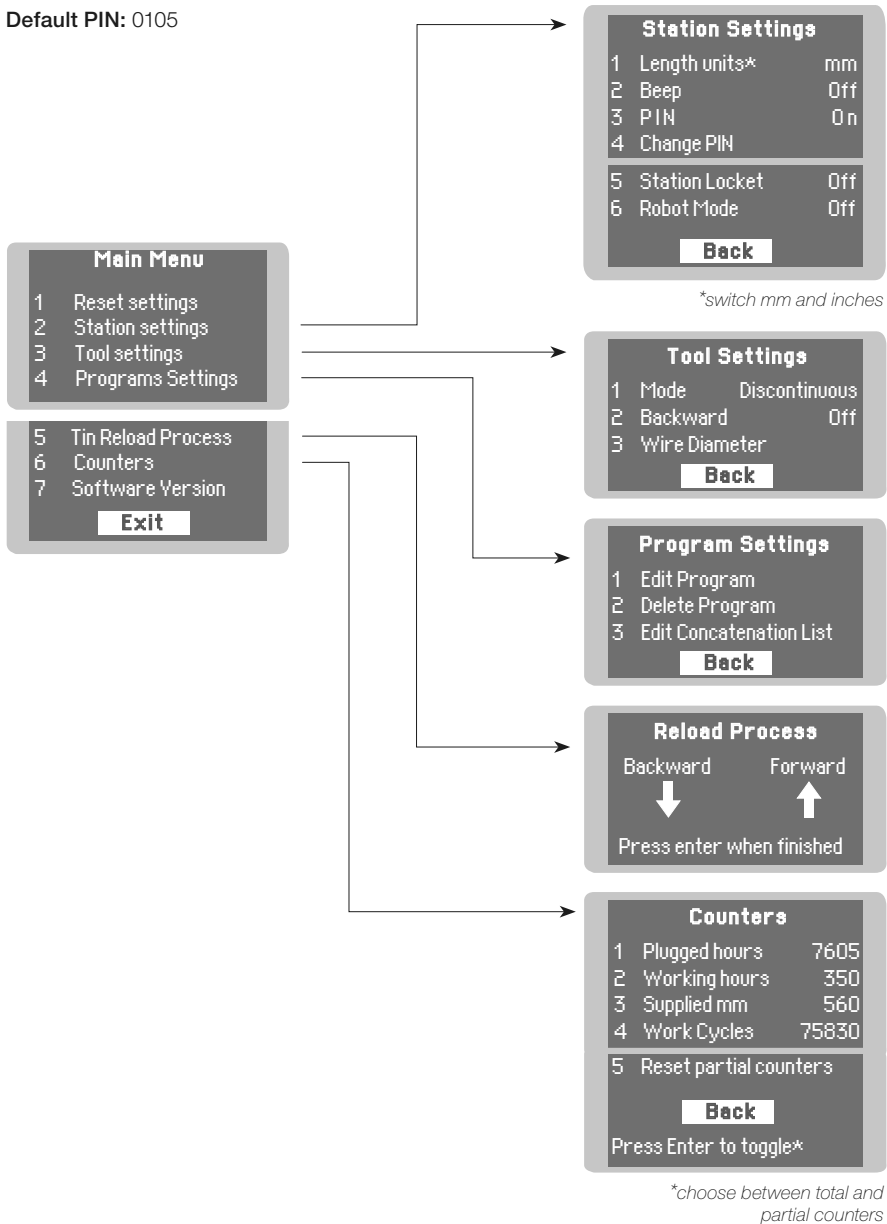

Accessories

Guide Kits

Various guide kits are available to choose from depending on the diameter of the welding wire used.



Solder Wire Ø	Ref. with Solder Wire Perforation	Solder Wire Ø	Ref. without Solder Wire Perforation
-	-	0.38 - 0.40 mm / 0.015 - 0.016 in	GSF04D-B
-	-	0.46 - 0.56 mm / 0.018 - 0.022 in	GSF05D-B
-	-	0.60 - 0.64 mm / 0.023 - 0.025 in	GSF06D-B
-	-	0.70 - 0.78 mm / 0.028 - 0.031 in	GSF07D-B
0.8 mm / 0.032 in	GSF08V-B	0.80 - 0.82 mm / 0.032 - 0.033 in	GSF08D-B
1.0 mm / 0.040 in	GSF10V-B	0.90 - 1.10 mm / 0.036 - 0.044 in	GSF10D-B
1.2 mm / 0.047 in	GSF12V-B	1.14 - 1.27 mm / 0.045 - 0.051 in	GSF12D-B
1.5 mm / 0.059 in	GSF15V-B	1.50 - 1.57 mm / 0.060 - 0.063 in	GSF15D-B
1.6 mm / 0.063 in	GSF16V-B	1.60 - 1.63 mm / 0.063 - 0.065 in	GSF16D-B
-	-	1.80 mm / 0.073 in	GSF18D-B

Tool Stand

Stand for SF280 Auto Solder-Wire Handle

Ref. SF-SE

It allows leaving the tool on a support when not in use and has a cable collector to keep the work space tidy.



Accessories

GSF Guide Kit for SF280
with Solder-Wire Perforation







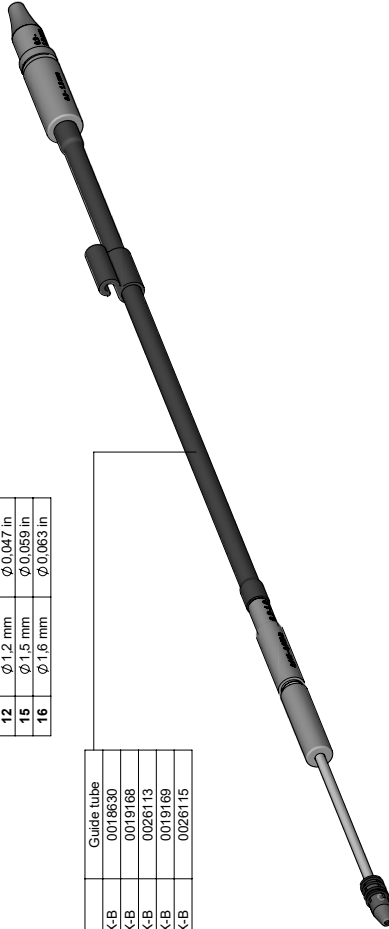

GSFXXV-B WITH SOLDER WIRE PERFORATION

XX	Wire diameter
	Diameter of use
08	Ø 0,8 mm
10	Ø 1,0 mm
12	Ø 1,2 mm
15	Ø 1,5 mm
16	Ø 1,6 mm

Guide tube
GSF08X-B
GSF10X-B
GSF12X-B
GSF15X-B
GSF16X-B



SPARE PARTS

Wire Ø	Outlet nozzle	Nozzle	Guide wheel	Blade	Blade clamp	Inlet nozzle	Interm. nozzle	Counter Wheel	Screws	Threaded screw
GSF 08V-B	0025270	0030913	 0021696 0021699 0023738 0019696 0025922	 0021555	 0018638	 0018632 0019170 0019171 0024233	 0024955 0024956 0024957 0024958 0024959	 0026693 0026694	 0026695 (x2) 0026694	 0026696 (x3)
GSF 10V-B	0021560									
GSF 12V-B	0025272									
GSF 15V-B	0025274									
GSF 16V-B	0025276									

Accessories

GSF Guide Kit for SF280 without Solder-Wire Perforation

GSFXXD-B WITHOUT SOLDER WIRE PERFORATION

XX	Wire diameter
	Diameter of use
04	Ø 0.38 - 0.40 mm Ø 0.015 - 0.016 in
05	Ø 0.46 - 0.56 mm Ø 0.018 - 0.022 in
06	Ø 0.60 - 0.64 mm Ø 0.023 - 0.025 in
07	Ø 0.70 - 0.78 mm Ø 0.028 - 0.031 in
08	Ø 0.80 - 0.82 mm Ø 0.032 - 0.033 in
10	Ø 0.90 - 1.10 mm Ø 0.036 - 0.044 in
12	Ø 1.14 - 1.27 mm Ø 0.045 - 0.051 in
15	Ø 1.50 - 1.57 mm Ø 0.060 - 0.063 in
16	Ø 1.60 - 1.63 mm Ø 0.063 - 0.065 in
18	Ø 1.80 mm Ø 0.073 in

GSF04X-B	Guide tube
GSF05X-B	0033048
GSF06X-B	0019521
GSF07X-B	0033049
GSF08X-B	0033050
GSF10X-B	0018630
GSF12X-B	0019168
GSF15X-B	0026113
GSF16X-B	0019169
GSF18X-B	0026115
GSF3051	0033051

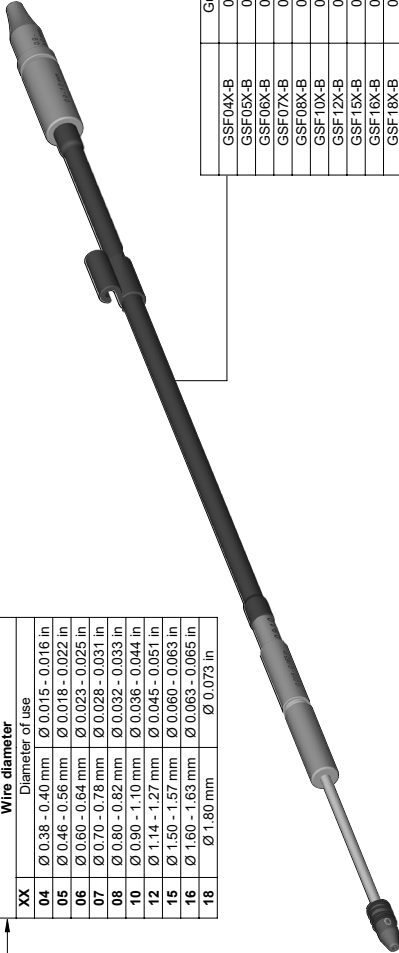

	Outlet Nozzle	Nozzle	Traction Wheel	Support Wheel	Inlet Nozzle	Intern. Nozzle	Counter Wheel	Screws	Threaded Screw
Wire Ø									
GSF04D-B	0032512	0030913	0019479	0020345	0019520	0024954	0026693 Suppl. in SF	0026695 (2x)	0026696 (3x)
GSF05D-B	0025268			0019519		0025293			
GSF06D-B	0022994			0019480		0025291			
GSF07D-B	0025289			0018632		0024955			
GSF08D-B	0025270			0019170		0024956			
GSF10D-B	0021560			0019171		0024957			
GSF12D-B	0025272			0019481		0024958			
GSF15D-B	0025274			0024233		0024959			
GSF16D-B	0025276			0024234		0024960			
GSF18D-B	0021559								

Maintenance

Before carrying out maintenance, always allow the equipment to cool down.

- Clean the station screen with a glass cleaner or a damp cloth.
- Use a damp cloth to clean the casing and the tool. Alcohol can only be used to clean the metal parts.
- Periodically check all cables and tubes.



- Replace a blown fuse as follows:

1. Pull off the fuse holder out and remove the worn fuse. If necessary use a tool to lever it off.

2. Insert the new fuse into the fuse holder and assemble it to the station.

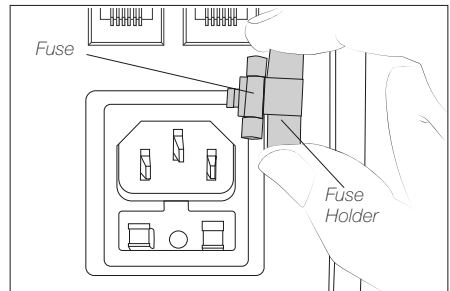
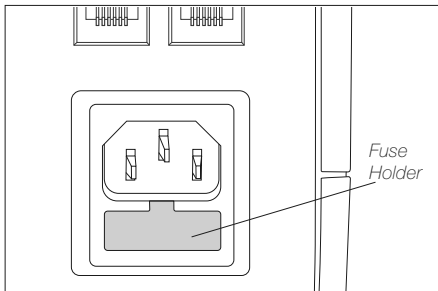

- Replace any defective or damaged parts. Use original JBC spare parts only.
- Repairs should only be performed by a JBC authorized technical service.

Safety



It is imperative to follow safety guidelines to prevent electric shock, injury, fire or explosion.

- Do not use the units for any purpose other than soldering or rework. Incorrect use may cause a fire.
- The power cord must be plugged into approved bases. Be sure that it is properly grounded before use. When unplugging it, hold the plug, not the wire.
- Do not work on electrically live parts.
- The tool should be placed in the stand when not in use in order to activate the sleep mode. The soldering tip or nozzle, the metal part of the tool and the stand may still be hot even when the station is turned off. Handle with care, including when adjusting the stand position.
- Do not leave the appliance unattended when it is on.
- Do not cover the ventilation grills. Heat can cause inflammable products to ignite.
- Avoid flux coming into contact with skin or eyes to prevent irritation.
- Be careful with the fumes produced when soldering.
- Keep your workplace clean and tidy. Wear appropriate protection glasses and gloves when working to avoid personal harm.
- Utmost care must be taken with liquid tin waste which can cause burns.
- This appliance can be used by children over the age of eight and also people with reduced physical, sensory or mental capabilities or lack of experience provided that they have been given adequate supervision or instruction concerning the use of the appliance and understand the hazards involved. Children must not play with the appliance.
- Maintenance must not be carried out by children unless supervised.

Specifications

SF**Automatic Solder-Wire Feeder Station**

Ref.: **SF-110VB** 100-120V 50/60Hz. Input fuse: T0.2A.

Ref.: **SF-210VB** 230V 50/60Hz. Input fuse: T0.125A.

- Compatible Solder Reel: Weight up to 1 kg / 2.2 lb
Diameter Max. 80 mm / 3.15 in
Height Max. 75mm / 2.95 in
Stand Axis ø 10 mm / 0.4 in
- Solder Wire Diameter ø 1.0 mm / ø 0.040 in
- Max. Wire Length 250 mm / 9.84 in
- Max. Forward Speed 120 mm/s / 4.72 in/s
- Max. Reverse Speed 120 mm/s / 4.72 in/s
- Ambient Operating Temp: 10 - 50 °C / 50 - 122 °F
- USB Connector Station-PC
- Robot Connector
- Dimensions / Net Weight: 140 x 150 x 120 mm / 2.32 kg
(L x W x H) 5.5 x 5.9 x 4.72 in / 5.11 lb
- Total package Dimensions / Weight: 368 x 368 x 195 mm / 3.23 kg
(L X W X H) 14.5 x 14.5 x 7.68 in / 7.12 lb

Complies with CE standards.
ESD safe.

JBC

Warranty

JBC's 2 year warranty covers this equipment against all manufacturing defects, including the replacement of defective parts and labor.

Warranty does not cover product wear or misuse.

In order for the warranty to be valid, equipment must be returned, postage paid, to the dealer where it was purchased.

Get 1 extra year JBC warranty by registering here:
<https://www.jbctools.com/productregistration/>
within 30 days of purchase.

If you register, you will receive e-mail notifications about new software updates for your registered product.



This product should not be thrown in the garbage.

In accordance with the European directive 2012/19/EU, electronic equipment at the end of its life must be collected and returned to an authorized recycling facility.

CE EAC UK
CA

www.jbctools.com

0028008-070325