

JBC

www.jbctools.com

Product
website



INSTRUCTION MANUAL



FAE022

Flexible Arm

This manual corresponds to the following reference:

FAE022

- Total length (tube compressed): 1.20 m / 47.24 in
- Max. operating distance: 1.00 m / 39.37 in (see page 4)

Packing List

The following items are included:



Flexible Arm 1 unit



Screws 3 units
DIN7982 - \varnothing 3.5x25 - black burnished
Ref. 0019142



Manual 1 unit
Ref. 0035573

Assembly Example

FAE 022

Flexible Arm \varnothing 50 mm
Bear in mind the installation dimensions (see page 5).

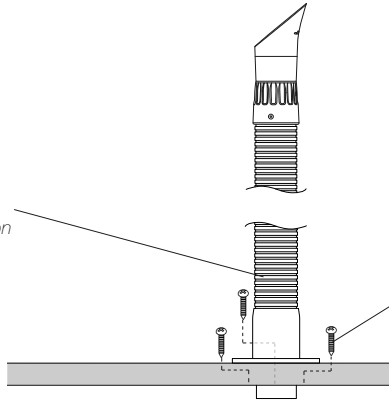

Fix the flange on your workbench with the supplied screws (more information on page 6).

FAE010

Flexible Hose \varnothing 50 mm
Total length: ~1.6 m / ~63 in

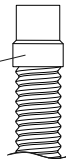

Connect the flexible hose to the flexible arm.

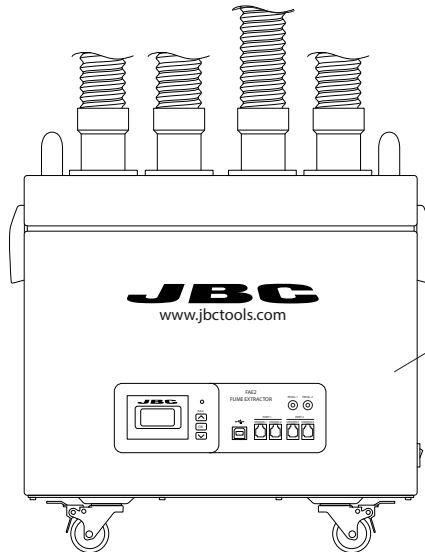

FAE2
Fume Extractor

How to use

Arm Installation

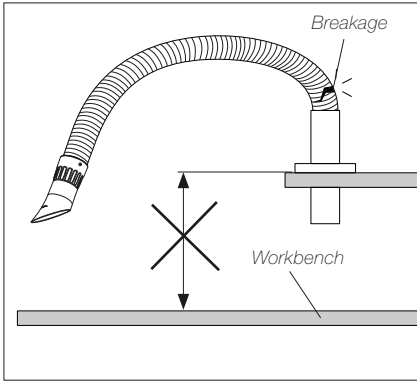

Do not install the flexible arm on shelves or levels higher than the workbench. Forced bending radii can cause the arm to break.

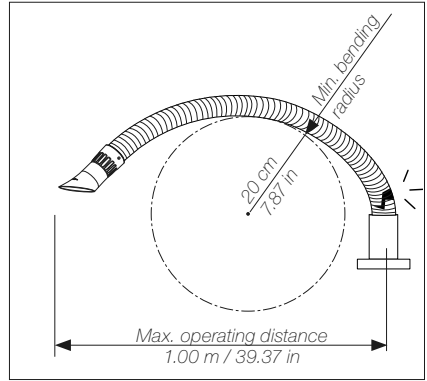

To avoid breaking the hose, do not extend it more than 100 cm / 39.37 in from the center of its base and do not go below the minimum bend radius of 20 cm / 7.87 in.

Arm Positioning

Thanks to the flexibility of the arm, its position can be adapted to the particular working environment and conditions.

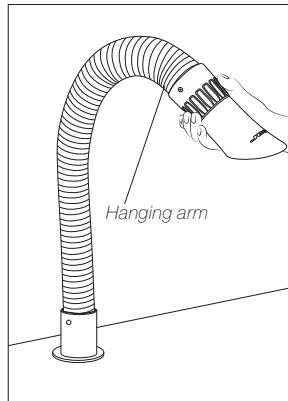

The arm can be used in an upright position with the nozzle hanging over the workplace ...

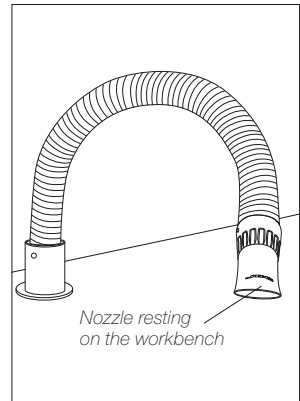

... or with the nozzle resting on the workbench.

Hose Compression

In case of breakage, the hose can be reconnected.

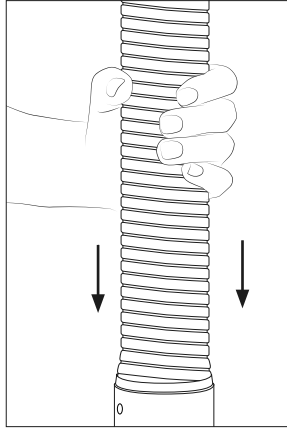

To reconnect the hose, align the two parts and push them firmly until they interlock.

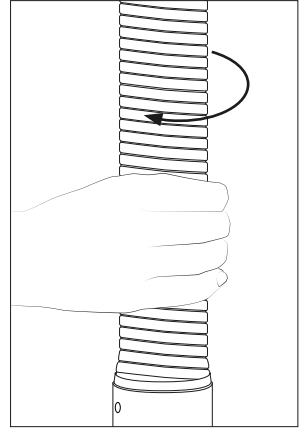

If the hose loses firmness, it must be recompressed.

To increase compression, turn the hose slightly clockwise. After the hose is compressed, readjust its position.

Nozzle Replacement

Nozzle and tube are connected to each other by means of a bayonet lock. This makes it easy to replace the nozzles.

Note: FAE022 is **only compatible with** nozzles FAE090, FAE091, FAE092 and FAE093.

It is **not compatible** with nozzles FAE080, FAE081, FAE082 and FAE083.

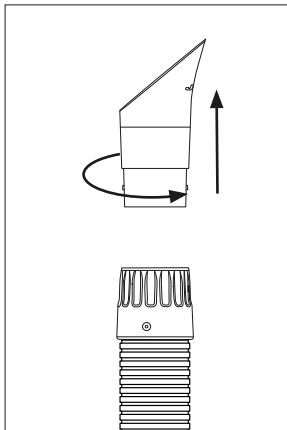

Disassemble the nozzle by holding the tube with one hand. With the other hand turn the nozzle counter-clockwise and pull it out.

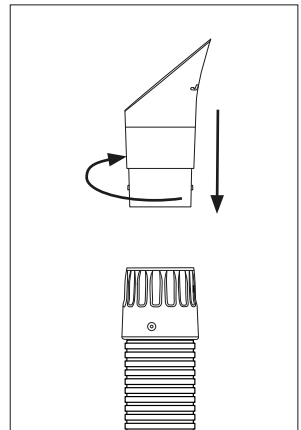

To install a new nozzle, turn the nozzle bayonet clockwise to lock it in place.

Dimensions Scheme for FAE022 Fixing

To assemble the flexible arm FAE020 (Ø50) for the first time, follow these instructions:

- First, make the large central hole in your workbench as shown in the drawing below.
- Place the FAE020 flange in the opening and mark the points for the three pilot holes.
- Take out the flange and drill the three holes at the marked spots. See the hole diameter on the dimension scheme:

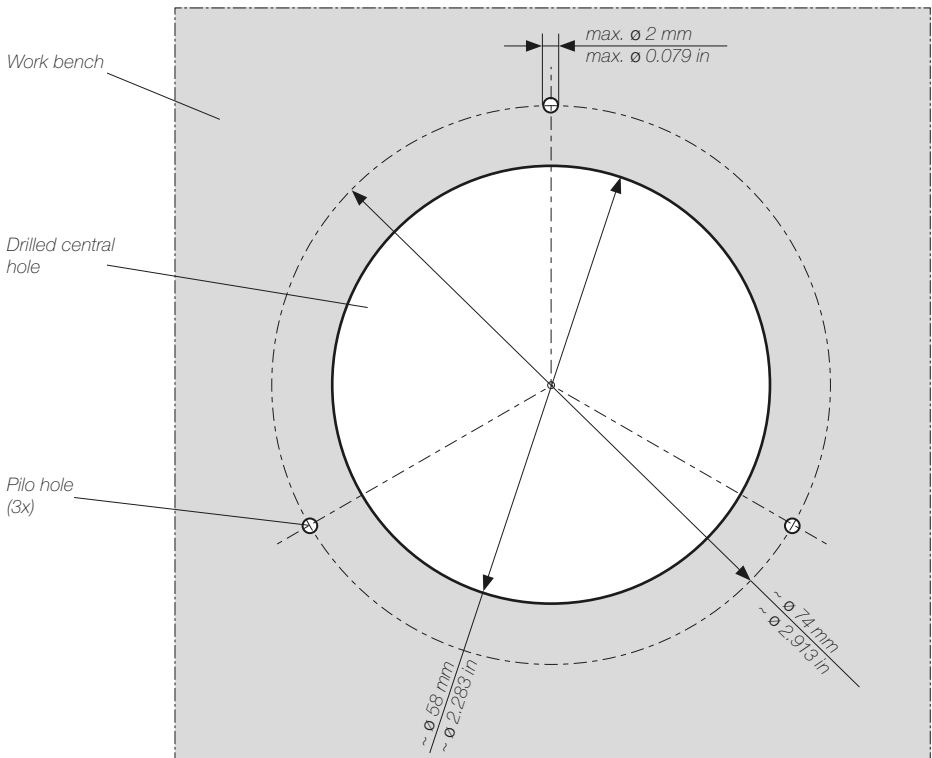

- Return the flexible to the center hole and align the holes in the flange with the pilot holes drilled in the workbench. Screw the arm to the bench using the three screws supplied with the arm.

Specifications

FAE022

Flexible Arm

Ref. **FAE022**

- Inner Tube Diameter: $\varnothing 50$ mm / $\varnothing 1.97$ in
- Total length (tube compressed): 1.20 m / 47.24 in
- Max. operating distance: 1.00 m / 39.37 in (see page 4)

- Total Net Weight: 1.65 kg / 3.64 lb
- Package Dimensions / Weight:
(L x W x H) 110 x 435 x 605 mm / 2.4 kg
4.33 x 17.13 x 23.82 in / 5.29 lb

Complies with CE standards.
ESD safe.

JBC

Warranty

JBC's 2 year warranty covers this equipment against all manufacturing defects, including the replacement of defective parts and labor.

Warranty does not cover product wear or misuse.

In order for the warranty to be valid, equipment must be returned, postage paid, to the dealer where it was purchased.



This product should not be thrown in the garbage.

In accordance with the European directive 2012/19/EU, electronic equipment at the end of its life must be collected and returned to an authorized recycling facility.

