

# JBC

[www.jbctools.com](http://www.jbctools.com)



## Soldering Station

Ref. BT-A

## Packing List

The following items should be included:

**Control Unit** ..... 1 unit  
Ref. BT-1A (120V)  
BT-2A (230V)  
BT-9A (100V)



**General Purpose Handle** ..... 1 unit  
Ref. T245-A



**Power Cord** ..... 1 unit  
Ref. 0009417 (100V/120V)  
0009401 (230V)



**Cartridges** ..... 2 units  
Ref. C245906 (x1)  
C245907 (x1)



**Brass Wool** ..... 1 unit  
Ref. CL6210

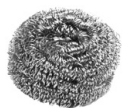

**Manual** ..... 1 unit  
Ref. 0008865



## Features

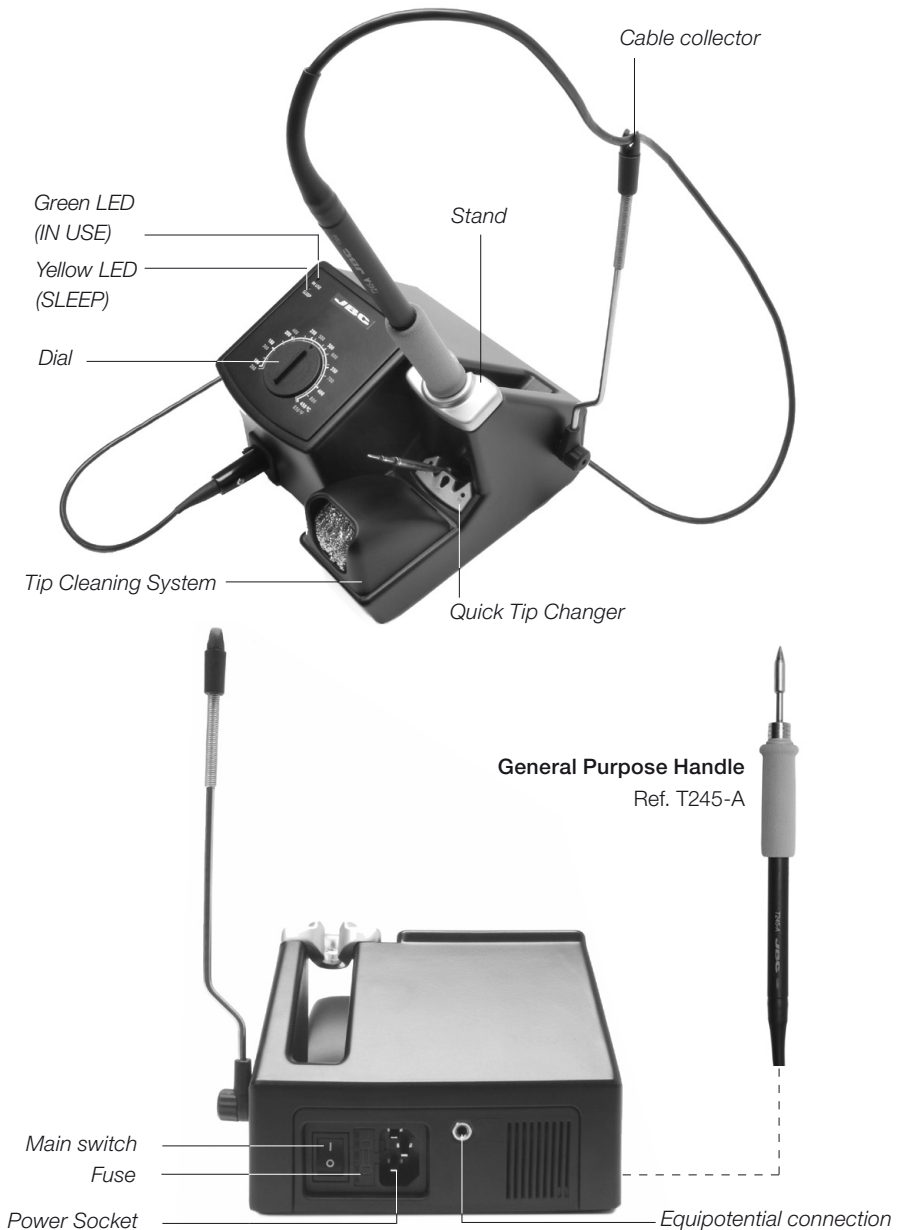

## Compatible Handles

### For general use

Works with C245 Cartridge range

#### General Purpose Handle

Ref. T245-A



#### Blue Handle

Ref. T245-PA



#### Non-slip Handle

Ref. T245-B



#### Soft Thermal Insulator Handle

Ref. T245-C



Easily replace the Grips for T245-A and T245-C using the slip-on tabs (Ref. 0016057 Supplied with 4 grips).

#### 1. Inserting tabs

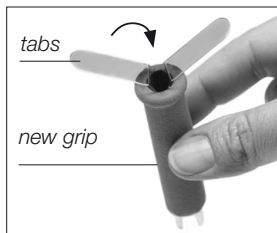

Put the slip-on tabs into the new grip.

#### 2. Inserting handle

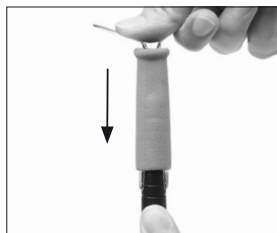

Slide the grip with the tabs onto the handle.

#### 3. Removing tabs

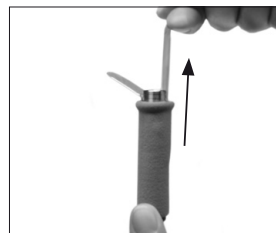

To remove the tabs, hold the grip and pull.

Note: All models are supplied with a 1.5 m cable.

### For precision use

Works with C210 Cartridge range

#### Precision Purpose Handle

Ref. T210-A



#### Blue Precision Handle

Ref. T210-PA

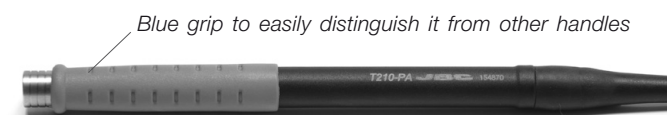

### For greater demands

**Important:** Only work with C245 cartridges when used with a CD station.

For intensive soldering jobs requiring continued high thermal power. They feature good thermal insulation and a screw which fixes the cartridge and prevents its rotation.

#### HD Purpose Handle

Ref. T470-A



#### HD Purpose Handle + 3m cable

Ref. T470-SA

#### Tri-lobed HD Handle

Ref. T470-ZA

For better handling of the tool.



#### Thermal Insulator HD Handle

Ref. T470-FA



#### Thermal Insulator HD Handle + 3m cable

Ref. T470-MA

Note: All models are supplied with a 1.5 m cable except those specified with 3 m.

## Quick Tip Changer

Save time and change cartridges safely without switching the station off.

### 1. Removing

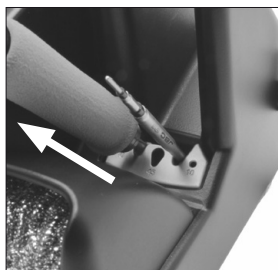

Place the handpiece in the extractor and pull to remove the cartridge.

### 2. Inserting

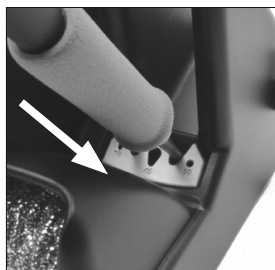

Place the handpiece on top of the new cartridge and press down slightly.

### 3. Fixing

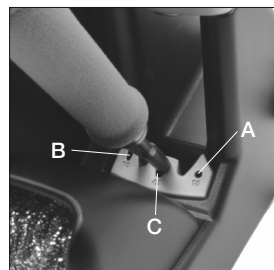

Use the holes for fixing the cartridge\* as follows:  
**A.** For straight C210.  
**B.** For curved C210.  
**C.** For C245.

### \*Important

It is essential to insert the cartridges as far as the mark for a proper connection.

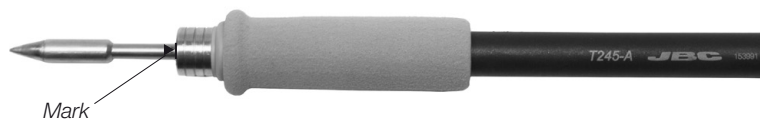

## Compatible cartridges

The BT stations work with C245 cartridges and T245/T470 handpieces or C210 cartridges with T210 handpieces. Find the model that best suits your soldering needs in [www.jbctools.com](http://www.jbctools.com)

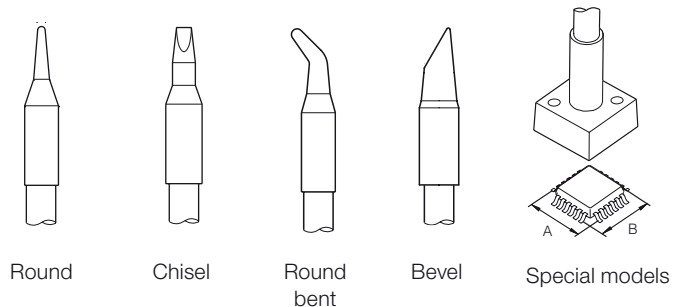

## Operation

The LEDs indicate the station's different working modes.

**1. Station without a tool connected:** The green IN USE light flashes with the sequence (- - - -).

**2. Tool out of the support:** The green IN USE light is permanently lit, indicating that the soldering iron tip is at working temperature.

**3. Tool in the support (sleep mode):** The yellow SLEEP light is permanently lit.

In order that the tool goes into sleep mode, the tool must be in its support and the programmed sleep temperature must be less than the temperature on the dial or the prefixed temperature.

**4. Station with previously fixed temperature.** (Only for users of the AC console).

Soldering iron out of support:

- If the dial is above the prefixed temperature, the green IN USE light is lit the majority of the time, switching off briefly at regular intervals (- - -).
- If the dial is below the prefixed temperature, the green IN USE light is off the majority of the time, lighting up briefly at regular intervals (- - -).
- If the dial is at the prefixed temperature, the green light is permanently lit.

### Errors

When the handpiece or the cartridge is in an open circuit, the green IN USE light flashes with the sequence (- - - -).

When the handpiece or the cartridge is in a short circuit, the green IN USE light flashes with the sequence (- - - -).

If any of the above mentioned causes is corrected, the station will start working automatically.

If the station is used continually in a overloaded condition for a period of time, the system will stop and both leds will flash simultaneously. Switch station off and on to reset and review the soldering application.



### AC Console



The original parameters of control unit can be modified using the AC console.

It is necessary to connect the console AC with software revision 7.0 or later to the BT in order to configure it (consult JBC for console software updates).

Previous versions only allow for reading of counters and do not allow for modification of parameters

Configuration possible:

- Fixing the working temperature.
- Selection of temperature units °C or °F.
- Modification of sleep temperatures and standby times.
- Adjustment of temperature.
- Reset the parameters back to factory settings.
- Read-out data:
  - Working hours.
  - Sleep cycles and sleep hours.
  - Cartridge and iron changes.
  - Program version.

## Maintenance

Before carrying out maintenance, always allow the equipment to cool.

- Clean the station screen with a glass cleaner or a damp cloth.
- Use a damp cloth to clean the casing and the tool. Alcohol can only be used to clean the metal parts.
- Periodically check that the metal parts of the tool and stand are clean so that the station can detect the tool status.
- Maintain tip surface clean and tinned prior to storage in order to avoid tip oxidation. Rusty and dirty surfaces reduce heat transfer to the solder joint.
- Periodically check all cables and tubes.
- Replace a blown fuse as follows:

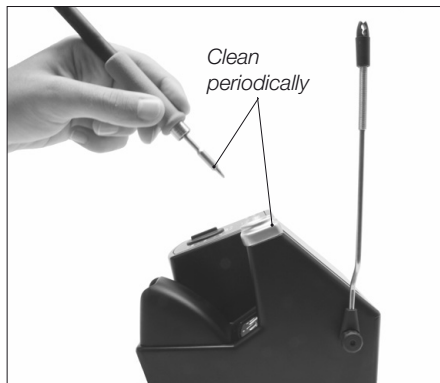

**1.** Pull off the fuse holder and remove the fuse. If necessary use a tool to lever it off.



**2.** Press the new fuse into the fuse holder and replace it in the station.

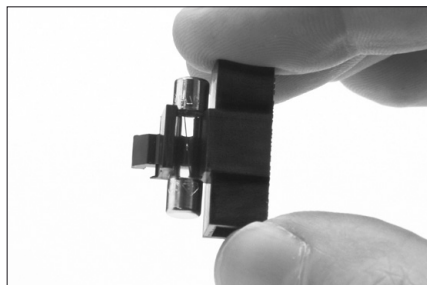

- Replace any defective or damaged pieces. Use original JBC spare parts only.
- Repairs should only be performed by a JBC authorized technical service.

## Safety



**It is imperative to follow safety guidelines to prevent electric shock, injury, fire or explosion.**

- Do not use the units for any purpose other than soldering or rework. Incorrect use may cause fire.
- The power cord must be plugged into approved bases. Be sure that it is properly grounded before use. When unplugging it, hold the plug, not the wire.
- Do not work on electrically live parts.
- The tool should be placed in the stand when not in use in order to activate the sleep mode. The soldering tip, the metal part of the tool and the stand may still be hot even when the station is turned off. Handle with care, including when adjusting the stand position.
- Do not leave the appliance unattended when it is on.
- Do not cover the ventilation grills. Heat can cause inflammable products to ignite.
- Use a "non residue" classified flux and avoid contact with skin or eyes to prevent irritation.
- Be careful with the fumes produced when soldering.
- Keep your workplace clean and tidy. Wear appropriate protection glasses and gloves when working to avoid personal harm.
- Utmost care must be taken with liquid tin waste which can cause burns.
- This appliance can be used by children over the age of eight and also persons with reduced physical, sensory or mental capabilities or lack of experience provided that they have been given adequate supervision or instruction concerning use of the appliance and understand the hazards involved. Children must not play with the appliance.
- Maintenance must not be carried out by children unless supervised.

Exploded View

**BT-2A 230V**  
**BT-1A 120V**  
**BT-9A 100V**  
**SOLDERING STATION**

SPARE PARTS	
<b>BT-2A / BT-1A / BT-9A:</b>	
-FRONT CIRCUIT	0007479
-ENCLOSURE	0011067

BT-2A 230V FUSE T-1A  
BT-1A 120V FUSE T-2A  
BT-9A 100V FUSE T-2A

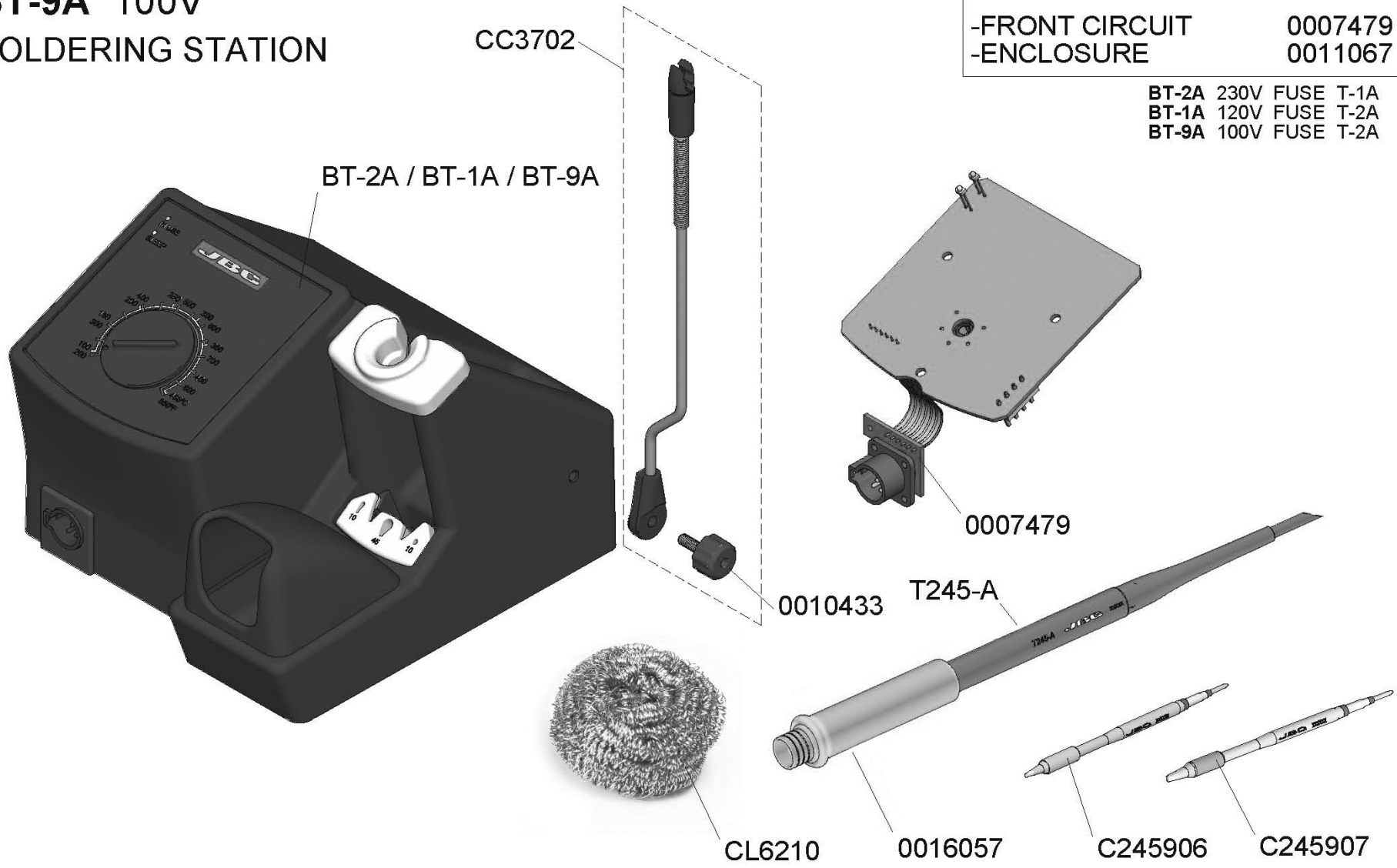



# Specifications

**BT-1A** 120V 50/60Hz. Input fuse: 2A. Output: 24V

**BT-2A** 230V 50/60Hz. Input fuse: 1A. Output: 24V

**BT-9A** 100V 50/60Hz. Input fuse: 2A. Output: 24V

- Weight: 2.6 Kg (5.7 lb)
- Dimensions: 162 x 153 x 115 mm
- Power: 75W
- Temperature range: 100-450°C (200-850 °F) (±5%)

Complies with CE standards

ESD protected housing "skin effect"

# JBC

## Warranty

JBC's 2 year warranty covers this equipment against all manufacturing defects, including the replacement of defective parts and labour.

Warranty does not cover product wear due to use or mis-use.

In order for the warranty to be valid, equipment must be returned, postage paid, to the dealer where it was purchased.



This product should not be thrown in the garbage.

In accordance with the European directive 2012/19/EU, electronic equipment at the end of their life must be collected and returned to an authorized recycling facility.