

JBC

www.jbctools.com

INSTRUCTION MANUAL



**GAL0405, GAL0608,
GAL0910, GAL1115, GAL1618**

Guide Kits for AL250

This manual corresponds to the following references:

- Ref. **0002399** - Ø 0.4 - 0.5 mm / 0.015 - 0.02 in
- Ref. **0002402** - Ø 0.6 - 0.8 mm / 0.023 - 0.03 in
- Ref. **0002401** - Ø 0.9 - 1.0 mm / 0.035 - 0.04 in
- Ref. **0002843** - Ø 1.1 - 1.5 mm / 0.043 - 0.06 in
- Ref. **0013915** - Ø 1.6 - 1.8 mm / 0.062 - 0.07 in

Packing List

The following items should be included:



Guide kit for AL250 1 unit
**Driver gear is included only in the Ø 1.1 - 1.5 mm & Ø 1.6 - 1.8 mm guide sets for a correct dragging of the solder wire.*

Manual 1 unit
Ref. 0033061

Guide Set Assembly

1. Unlock the dragging mechanism.

2. Place the guide set and tighten the screws.

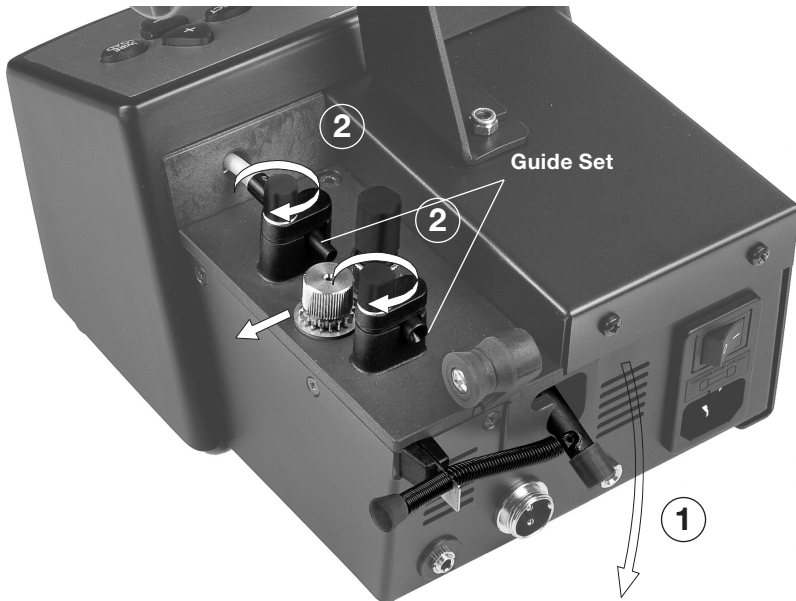

3. Insert the guide set in the tool. You must leave a gap of 8-10 mm between the cartridge tip and the end of the guide tube.

4. Tighten the guide tube screw to block the position of the guide.

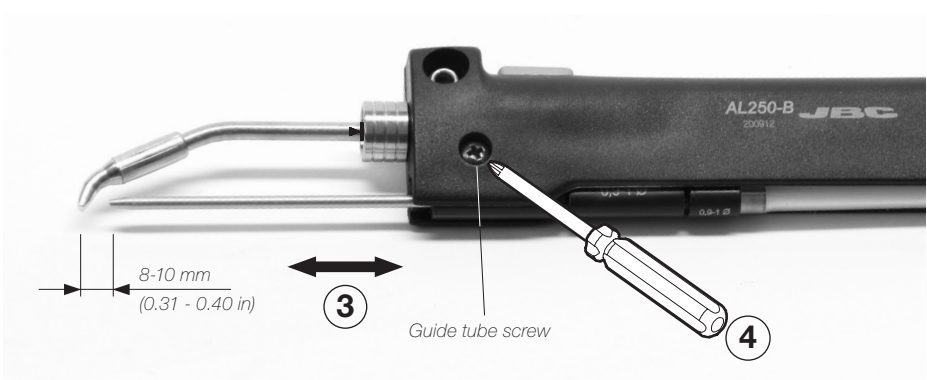

5. Draw the solder wire from the reel to the entrance of the guide tube.

6. Close the dragging mechanism.

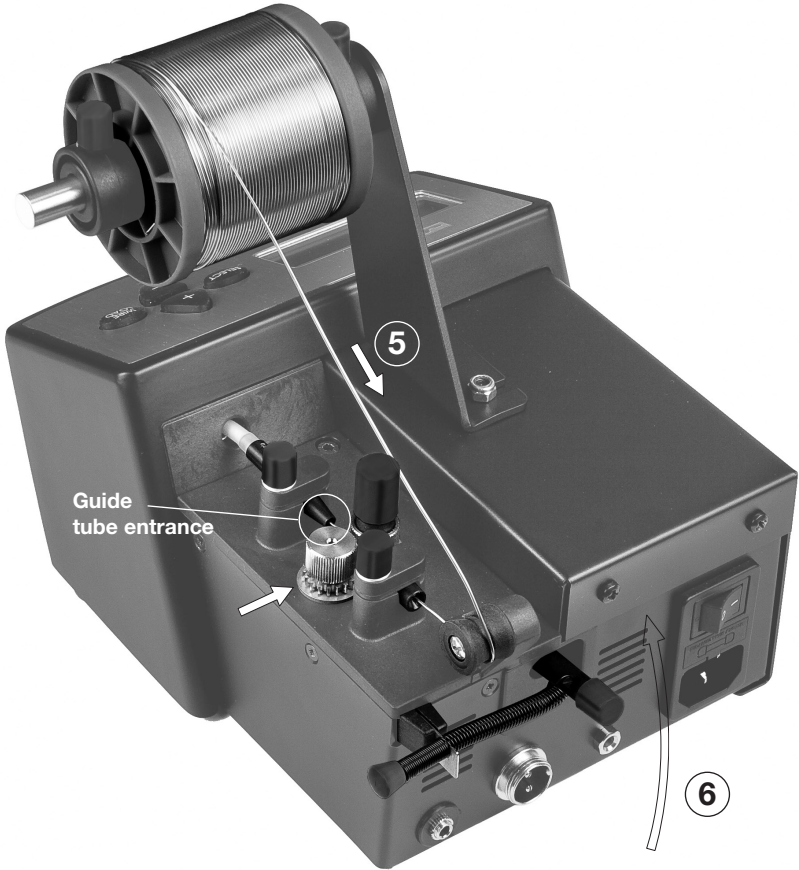

7. Connect the Auto-feed Iron to the station and switch it on. Lift the auto-feed iron from the stand and press the WIRE LOAD key until

the solder wire comes out of the end of the guide tube.



**LOADING
SOLDER WIRE**

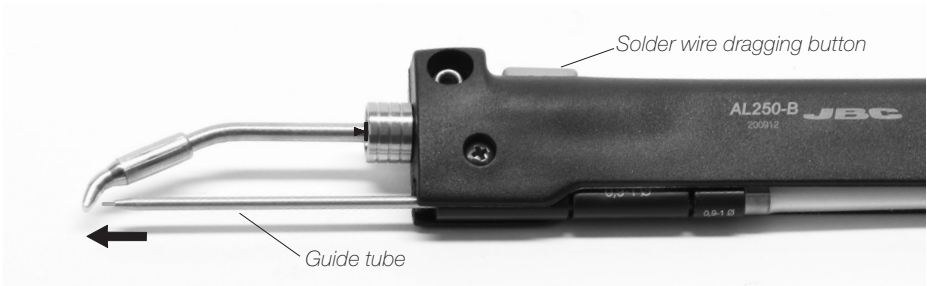

Clutch Regulation

A. Adjust the dragging strength to allow the forwarding of the solder wire and to avoid stall and or clogging situations when any cause arises.

B. Tighten the dragging mechanism.

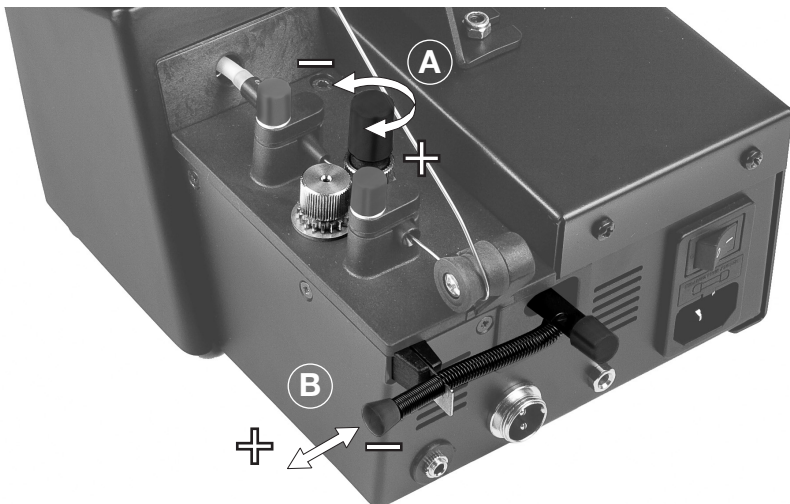

Driver Gear Replacement

When using solder wire within \varnothing 1.1 and \varnothing 1.8 mm you must use the driver gear (ref. 0002863) for the dragging system to function properly. This gear replaces the one supplied with the station. To do this, follow these instructions:

1. Open the dragging mechanism.



2. Unscrew the clutch regulation assembly and pull it out.



3. Pull out the standard driver gear supplied with the station.



4. Place the new driver gear (ref. 0002863) supplied with the guide set.



5. Place the regulation assembly and screw it. Close the dragging mechanism.



Specifications

GAL0405, GAL0608, GAL0910, GAL1115, GAL1618

Guide Kit for AL250

Ref. **0002399** - Ø 0.4 - 0.5 mm / 0.015 - 0.02 in

Ref. **0002402** - Ø 0.6 - 0.8 mm / 0.023 - 0.03 in

Ref. **0002401** - Ø 0.9 - 1 mm / 0.035 - 0.04 in

Ref. **0002843** - Ø 1.1 - 1.5 mm / 0.043 - 0.06 in

Ref. **0013915** - Ø 1.6 - 1.8 mm / 0.062 - 0.07 in

- Net weight: 28 g / 0.06 lb
- Package dimensions / weight: 245 x 185 x 45 mm / 100 g
(L x W x H) 9.65 x 7.28 x 1.77 in / 0.22 lb

Complies with CE standards.
ESD Safe.

JBC

Warranty

JBC's 2 year warranty covers this equipment against all manufacturing defects, including the replacement of defective parts and labour.

Warranty does not cover product wear or misuse.

In order for the warranty to be valid, equipment must be returned, postage paid, to the dealer where it was purchased.

Get 1 extra year JBC warranty by registering here:
<https://www.jbctools.com/productregistration/>
within 30 days of purchase.



This product should not be thrown in the garbage.

In accordance with the European directive 2012/19/EU, electronic equipment at the end of its life must be collected and returned to an authorized recycling facility.

**CE EAC UK
CA**

www.jbctools.com

0004111-080124